

**FABRICATION OF A PARALLEL AND COUNTER FLOW
HEAT EXCHANGER**

*A Project report submitted in partial fulfillment of the requirements for the Award of the
Degree of*

**BACHELOR OF TECHNOLOGY
IN
MECHANICAL ENGINEERING**

Submitted by

B. KARTHIK (315126520023)
CH. VYSHALI (315126520033)
D.NAGENDRA KUMAR (315126520039)
G. PRATHIK ARJUN (315126520053)
D.NITESH (315126520041)

under the esteemed guidance of

Mr. P. CHANDRA SEKHAR (M.Tech)

Assistant Professor

DEPARTMENT OF MECHANICAL ENGINEERING



**ANIL NEERUKONDA INSTITUTE OF TECHNOLOGIES AND SCIENCES
(Autonomous)**

**(Affiliated to AU, Approved by AICTE & Accredited by NBA & Approved by
NAAC with A grade)**

SANGIVALASA, BHEEMUNIPATNAM, VISAKHAPATNAM-531162

(2015-2019)

ANIL NEERUKONDA INSTITUTE OF TECHNOLOGY AND SCIENCES

(Autonomous)

**(Affiliated to AU, Approved by AICTE & Accredited by NBA & Approved by
NAAC with A grade)**

SANGIVALASA, BHEEMUNIPATNAM, VISAKHAPATNAM-531162

(2015-2019)



CERTIFICATE

This is to certify that the project report entitled “**Fabrication Of A Parallel And Counter Flow Heat Exchanger**” has been carried out by **B.Karthik (315126520023)**, **Ch.Vyshali (315126520033)**, **D.Nagendra Kumar (315126520039)**, **G.Prathik Arjun (315126520053)** and **D.Nitesh (315126520041)** under the supervision and guidance of **Mr.P.Chandra Sekhar**, in partial fulfillment of the requirements for the Degree of Bachelor of Mechanical Engineering by Andhra University, Visakhapatnam.

APPROVED BY

Dr. B. NAGARAJU

Professor, Head of the Department

Dept. of Mechanical Engineering

ANITS, Visakhapatnam

PROJECT GUIDE

P. Chandra Sekhar

Mr. P. CHANDRA SEKHAR

Assistant Professor

Dept. of Mechanical Engineering

ANITS, Visakhapatnam

SIGNATURE OF THE HOD

PROFESSOR & HEAD

Department of Mechanical Engineering
ANIL NEERUKONDA INSTITUTE OF TECHNOLOGY & SCIENCES
Sangivalasa-531162 VISAKHAPATNAM Dist. A.P.

P. Chandra Sekhar

SIGNATURE OF THE GUIDE

THIS PROJECT IS APPROVED BY THE BOARD OF EXAMINERS

INTERNAL EXAMINER:

 13/4/19

PROFESSOR & HEAD
Department of Mechanical Engineering
ANK NEERUKONDA INSTITUTE OF TECHNOLOGY & SCIENCE
Sangivalasa-531 162 VISAKHAPATNAM Dist. A.P.

EXTERNAL EXAMINER:

 13/4/19

ACKNOWLEDGEMENT

The gratification that results in a successful completion of a task would be incomplete without mentioning the key individuals who made it possible, who not only encouraged and boosted our morale but also got us through the snags in our work. We take in a great pleasure presenting a project, which is a result of research and knowledge.

We are extremely thankful to our honorable principal **Prof. T.Subrahmanyam** for giving us the opportunity to carry out the project.

We would like to take the privilege to thank the Head of Department **Prof. B. Nagaraju** , for permitting us to utilize the resources and providing the lab facilities, we would also like to thank the staff members of our department and lab technicians who directly or indirectly helped us in successful completion of the project.

We feel exceptionally grateful to **Shri P. Chandra Sekhar**, our project guide who shared his expertise and made us understand the profundity of the topic all the while piquing our interest to work day and night for the project.

We also would like to thank our friends and the college staff who extended their support towards the successful completion of the project.

B. Karthik	315126520023
Ch. Vyshali	315126520033
D.Nagendra Kumar	315126520039
G. Prathik Arjun	315126520053
D.Nitesh	315126520041

ABSTRACT

Heat Exchangers play a vital role in industries like power plants, chemical industries, pharmaceuticals etc. Of many Heat exchangers available double pipe heat exchangers are well known for their simplicity and Robustness. A Double pipe Heat exchanger (counter current and parallel current) for laboratory purpose costs in range of 40000-60000 rupees in market as material used for pipes highly heat resisting steel alloys.

The present work is an effort to fabricate to minimize the cost of Double pipe Heat Exchanger by making modifications which include replacing material of outer pipe with optimal material in terms of cost and quality for lab purpose. Excluding magnetic pump where gravity fulfils its function. Even dimensions are minimized to fit in available place.

LIST OF CONTENTS

Description	page no.
CHAPTER-1.....	1
1 INTRODUCTION.....	2
1.1 Heat Exchanger:.....	2
1.2 Basic Principles Underlying Heat Exchangers:.....	4
1.3 Types of Flows In A Heat Exchangers:.....	5
1.3.1 Counter Flow:.....	6
1.3.2 Parallel Flow:.....	6
1.3.3 Crossflow:.....	6
1.3.4 Hybrid Flow:.....	6
1.4 Heat Exchanger Types:.....	7
1.4.1 Shell And Tube Heat Exchanger:.....	8
1.4.2 Plate Heat Exchangers:.....	9
1.4.3 Double Pipe Heat Exchanger:.....	10
1.5 Construction Method:.....	11
1.6 Heat Exchanger Components and Materials:.....	14
1.7 Heat Transfer Mechanism:.....	14
1.8 Condensers, Evaporators, and Boilers:.....	15
1.9 Other Heat Exchanger Variants:.....	15
1.10 Heat exchanger Selection Consideration:.....	15
1.10.1 Fluid Type, Stream and Properties:.....	16
1.10.2 Thermal Outputs:.....	17
1.10.3 Size Limitations:.....	17
1.10.4 Cost:.....	17
1.11 Design Optimization:.....	18
1.12 Applications of Heat Exchangers:.....	18
1.13 Thermocouple:.....	21

1.13.1	Thermocouple Working Principle:	21
1.13.2	Thermocouple Working:	22
1.13.3	Types of Thermocouples:	22
CHAPTER-2.....		24
2	LITERATURE REVIEW	25
CHAPTER-3.....		28
3	PROBLEMSTATEMENT.....	29
CHAPTER-4.....		30
4	DESIGN AND FABRICATION	31
4.1	Design:	31
4.1.1	Dimensions:	32
4.2	Fabrication:.....	32
4.2.1	Components used in Fabrication:.....	33
4.2.2	Experimental Setup:.....	36
CHAPTER-5.....		37
5	EXPERIMENT PROCEDURE	38
CHAPTER-6.....		39
6	OBSERVATIONS AND CALCULATIONS	40
6.1	Calculation Of Heat Transfer Rate.....	41
6.2	Overall Heat Transfer Coefficient:.....	42
6.3	Parallel Flow	42
6.3.1	Heat Transfer Rate:	43
6.3.2	LMTD	43
6.3.3	Overall Heat Transfer Coefficient	44
6.4	Counter Flow.....	44
6.4.1	Heat Transfer Rate	45
6.4.2	LMTD	45
6.4.3	Overall Heat Transfer Coefficient	46
6.5	Precautions:	46

6.6 Result:.....	46
CHAPTER-7.....	47
7 CONCLUSION	48
REFERENCES.....	49

LIST OF FIGURES

Figure 1 Heat exchanger	3
Figure 2 Types Of Heat Transfer In Heat Exchangers	7
Figure 3 Classification Of Heat Exchangers.....	7
Figure 4 Shell And Tube Heat Exchanger	8
Figure 5 Plate Heat Exchanger	9
Figure 6 Double Pipe Heat Exchanger.....	10
Figure 7 Modes Of Flow.....	11
Figure 8 Heat Exchanger Classification By Construction	12
Figure 9 Heat Transfer In A Rotary-Type Regenerator.....	14
Figure 10 Thermocouple Circuit.....	22
Figure 11 Thermocouple potential vs Temperature plot.....	23
Figure 12 T-Joint.....	33
Figure 13 Ball Valve.....	33
Figure 14 Reducer.....	34
Figure 15 Elbow Joint.....	34
Figure 16 Thermocouple.....	35
Figure 17 CPVC Adhesive.....	35
Figure 18 CPVC Pipes.....	36
Figure 19 Experimental Set Up.....	36

LIST OF TABLES

Table 1 Industries and Applications of Heat Exchangers by Type.....	19
Table 2 Parallel Flow	40
Table 3 Counter Flow	40

NOMENCLATURE

q_h = heat transferred through hot fluid

q_c = heat transferred through cold fluid

T_{ho} = outlet temperature of hot fluid

T_{hi} = inlet temperature of hot fluid

T_{co} = outlet temperature of cold fluid

T_{ci} = inlet temperature of cold fluid

A_i = Area of Inner Tube

A_o = Area of Outer Tube

m_h = mass flow rate of hot fluid inlet

m_c = mass flow rate of cold fluid inlet

C_p = specific heat constant of water

ΔT_{lm} = logarithmic mean temperature difference

U = overall heat transfer coefficient

d_1 = Inner diameter of copper

d_2 = Outer diameter of copper

CHAPTER-1

1 INTRODUCTION

1.1 Heat Exchanger:

Heat exchanger is a device which facilitates transfer of heat from hot fluid to cold fluid without the mixing of these fluids. In process plants it is necessary to control the temperature of incoming and outgoing process streams. These streams can either be gases or liquids. Heat exchangers raise or lower the temperature of these streams by transferring heat to or from the stream. The fluids may be separated by a solid wall to prevent mixing or they may be in direct contact. The temperature gradient or differences in temperature is the driving force for heat transfer.

They are widely used in space heating, refrigeration, air conditioning, power stations, chemical plants, petrochemical plants, petroleum refineries, natural gas processing and sewage treatment. The classic example of a heat exchanger is found in an IC engine in which a circulating fluid known as engine coolant flows through radiator coils and air flows past the coils, which cools the coolant and heats the incoming air.

Temperature is the average kinetic energy in the molecules of a substance. Heat exchangers are used to transfer that energy from one substance to another. In process plants it is necessary to control the temperature of incoming and outgoing process streams. These streams can either be gases or liquids. Heat exchangers raise or lower the temperature of these streams by transferring heat to or from the stream.

Heat exchangers are devices that exchange the heat between two fluids of different temperatures that are separated by a solid wall. The temperature gradient or differences in temperature is the driving force for heat transfer.

Transfer of heat occurs in three modes: Radiation, Conduction and Convection.

In the use of heat exchangers, radiation does not take place. However, in comparison to conduction and convection, radiation does not play a major role.

Conduction occurs as the heat from the higher temperature fluid passes through the solid pipe wall. To maximize the heat, transfer the wall should be thin and made of a very conductive material. The biggest contribution to heat transfer in a heat exchanger is made through convection.

In heat exchanger, forced convection allows for the transfer of heat of one moving stream to another moving stream. With convection, as heat is transferred through the pipe wall it is mixed into the stream and the flow of the stream removes the transferred heat. This maintains a temperature gradient between the two fluids.

The double pipe heat exchanger is one of the simplest types of heat exchangers. It is called double pipe heat exchanger because one fluid flows inside a pipe and the other fluid flows between that pipe and another pipe that surrounds the first. This is concentric tube construction.

Flow in a double-pipe heat exchanger can be co-current or countercurrent. There are two flow configurations: co-current is when the flow of the two streams is in the same direction. Countercurrent is when the flow of the streams is in opposite directions.

As conditions in the pipes change: inlet temperatures, flow rates, fluid properties, fluid composition etc.; the amount of heat transferred also changes. This transient behavior leads to change in process temperatures, which will lead to a point where the temperature distribution becomes steady.

When heat is beginning to be transferred, this changes the temperature of the fluids. Until these temperatures reach a steady state, their behavior is dependent on time. In the double pipe heat exchanger, a hot process fluid flowing through the inner pipe transfers its heat to the cooler fluid flowing in the outer pipe. The system is in steady state until conditions change such as flowrate or inlet temperature.

These changes in conditions cause the temperature distribution to change with time until a new steady state is reached. The new steady state will be observed once the inlet and outlet temperatures for the process and coolant fluid becomes stable.



Figure 1 Heat exchanger

1.2 Basic Principles Underlying Heat Exchangers:

Regardless of the type and design, all heat exchangers operate under the same fundamental principles—namely the Zeroth, First, and Second Laws of Thermodynamics—which describe and dictate the transference or “exchange” of heat from one fluid to another.

- The **Zeroth Law of Thermodynamics** states that thermodynamic systems that are in thermal equilibrium have the same temperature. Furthermore, if two systems are each in thermal equilibrium with a third system, then the two former systems must be in equilibrium with each other; thus, all three systems are of the same temperature. This law, preceding the three other Laws of Thermodynamics in order but not in development, not only expresses thermal equilibrium as a transitive property but also defines the concept of temperature and establishes it as a measurable property of thermodynamic systems.

$$\Delta U_{\text{SYSTEM}} = -\Delta U_{\text{surrounding}}$$

- The **First Law Of Thermodynamics** builds upon the Zeroth Law, establishing internal energy (U) as another property of thermodynamic systems and indicating the influence of heat and work on a system’s internal energy and the surrounding environment’s energy. Additionally, the first law—also referred to as the Law of Conversation of Energy—essentially states that energy cannot be created or destroyed, only transferred to another thermodynamic system or converted to another.

For example, if heat flows into the system from its surroundings, there is a corresponding increase in the internal energy of the system and a decrease in the energy of the surrounding environment. This principle can be illustrated by the following equation, where ΔU_{SYSTEM} represents the internal energy of the system, and $\Delta U_{\text{ENVIRONMENT}}$ represents the internal energy of the surrounding environment:

- The **Second Law Of Thermodynamics** establishes entropy (S) as an additional property of thermodynamic systems and describes the natural and invariable tendency of the universe, and any other closed thermodynamic system, to increase in entropy over time. This principle can be illustrated by the following equation

where ΔS represents the change in entropy, ΔQ represents the change in the heat added to the system, and T represents the absolute temperature

$$\Delta s = \frac{\Delta Q}{T}$$

It is also used to explain the tendency of two isolated systems—when allowed to interact and free from all other influences—to move towards thermodynamic equilibrium. As established by the Second Law, entropy can only increase, never decrease; consequently, each system, as the entropy increases, invariably moves towards the highest value achievable for said system. At this value, the system reaches a state of equilibrium where entropy can no longer increase (as it is at the maximum), nor decrease, as that action would violate the Second Law. Therefore, the only system changes possible are the ones in which entropy does not experience change (i.e., the ratio of the heat added or subtracted to the system to the absolute temperature remains constant).

Altogether, these principles dictate the underlying mechanisms and operations of heat exchangers; the Zeroth law establishes temperature as a measurable property of thermodynamic systems, the First Law describes the inverse relationship between a system's internal energy (and its converted forms) and that of its surrounding environment, and the Second Law expresses the tendency for two interacting systems to move towards thermal equilibrium. Thus, heat exchangers function by allowing a fluid of higher temperature (F_1) to interact—either directly or indirectly—with a fluid of a lower temperature (F_2), which enables heat to transfer from F_1 to F_2 to move towards equilibrium. This transfer of heat results in a decrease in temperature for F_1 and an increase in temperature for F_2 . Depending on whether the application is aimed towards heating or cooling a fluid, this process (and devices which employ it) can be used to direct heat towards or away from a system, respectively.

1.3 Types of Flows In A Heat Exchangers:

In order to discuss heat exchanger, it is necessary to provide some form of categorization. There are two approaches which are generally considered. The first considers the flow configuration within heat exchanger while the second is based on classification of equipment type primarily by construction.

Classification of Heat Exchangers By Flow Configuration:

- Counter flow
- Parallel flow
- Cross flow
- Hybrids such as Cross Counter flow and Multi Pass flow

1.3.1 Counter Flow:

Countercurrent flow heat exchangers, also known as counter flow heat exchangers, are designed such that the fluids move antiparallel (i.e., parallel but in opposite directions) to each other within the heat exchanger. The most commonly employed of the flow configurations, a counter flow arrangement typically exhibits the highest efficiencies as it allows for the greatest amount of heat transference between fluids and, consequently, the greatest change in temperature.

1.3.2 Parallel Flow:

Co current flow heat exchangers, also referred to as parallel flow heat exchangers, are heat exchanging devices in which the fluids move parallel to and in the same direction as each other. Although this configuration typically results in lower efficiencies than a counter flow arrangement, it also allows for the greatest thermal uniformity across the walls of the heat exchanger.

1.3.3 Crossflow:

In crossflow heat exchangers, fluids flow perpendicularly to one another. The efficiencies of heat exchangers which employ this flow configuration fall between that of countercurrent and co current heat exchangers.

1.3.4 Hybrid Flow:

Hybrid flow heat exchangers exhibit some combination of the characteristics of the previously mentioned flow configurations. For example, heat exchanger designs can employ multiple flow passes and arrangements (e.g., both counter flow and crossflow arrangements) within a single heat exchanger. These types of heat exchangers are typically used to accommodate the limitations of an application, such as space, budget costs, or temperature and pressure requirements.

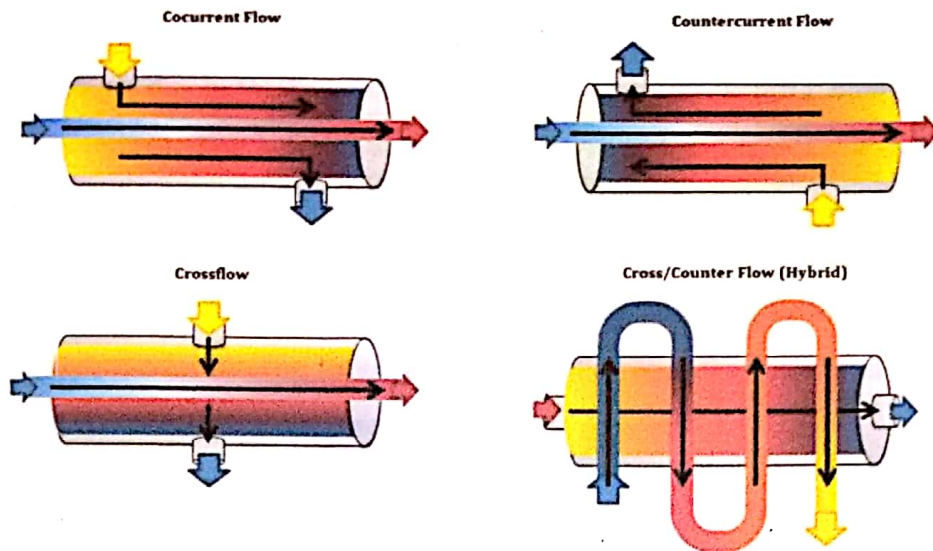

Figure 2 Types Of Heat Transfer In Heat Exchangers

1.4 Heat Exchanger Types:

A heat exchanger is a device used to transfer heat between two or more fluids. The fluids can be single or two phase and depending on the exchanger type it may be separated or can be in direct contact. Devices involving energy sources such as nuclear fuel pins or fired heaters are not normally regarded as heat exchangers although many of the principals involved in their design are the same.

This section briefly describes some of the common types of heat exchangers explaining their respective function and mechanisms.

Classification of Heat Exchangers

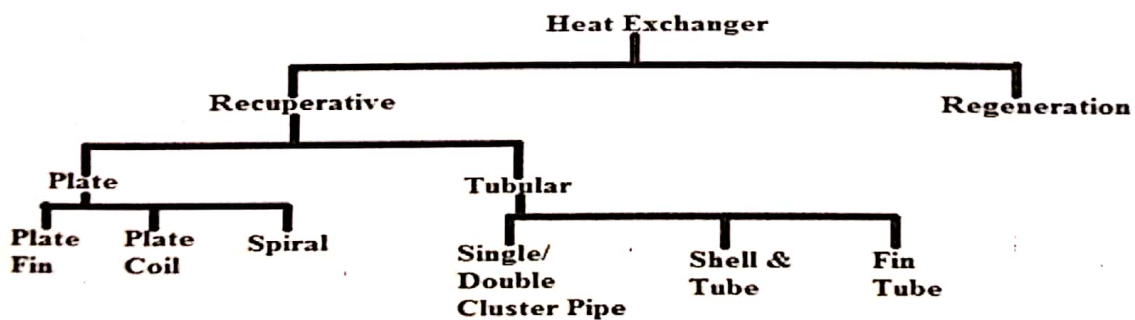

Figure 3 Classification Of Heat Exchangers

1.4.1 Shell And Tube Heat Exchanger:

The Shell and Tube Heat Exchangers are one of the most popular types of exchanger due to the flexibility the designer must allow for a wide range of pressures and temperatures. There are two main categories of Shell and Tube exchanger. A shell and tube exchanger consist of several tubes mounted inside a cylindrical shell. The figure illustrates a typical unit that may be found in a petrochemical plant. Two fluids can exchange heat, one fluid flows over the outside of the tubes while the second fluid flows through the tubes. The fluids can be single or two phase and can flow in a parallel or a cross/counter flow arrangement.

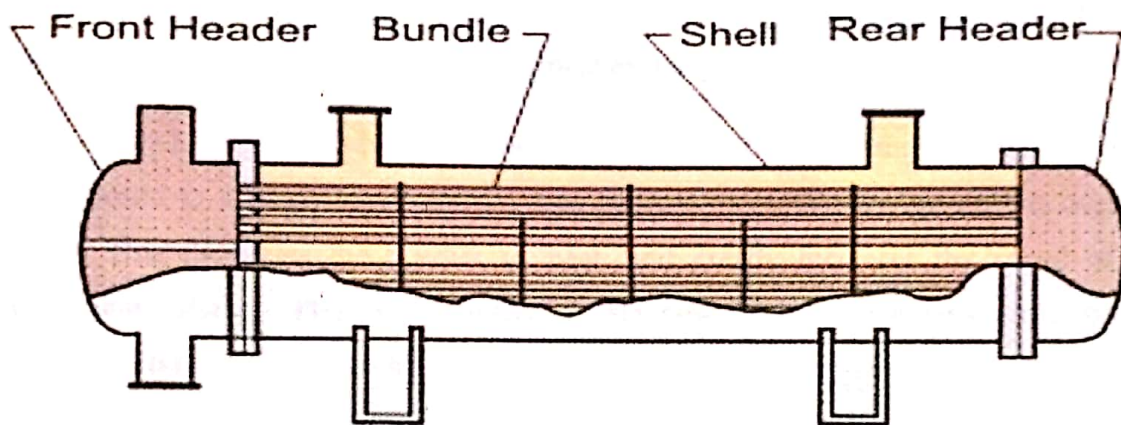

Figure 4 Shell And Tube Heat Exchanger

The Shell And Tube Exchanger Consist Of Four Major Parts.

- **Front Header**—this is where the fluid enters the tube side of the exchanger. It is sometimes referred to as the Stationary Header.
- **Rear Header**—this is where the tube side fluid leaves the exchanger or where it is returned to the front header in exchangers with multiple tube side passes.
- **Tube bundle**—this comprises of the tubes, tube sheets, baffles and tie rods etc. to hold the bundle together.
- **Shell**—this contains the tube bundle.

The popularity of shell and tube exchangers has resulted in a standard nomenclature being developed for their designation and use by the Tubular Exchanger Manufacturers Association (TEMA) standard. In general, shell and tube exchangers are made of metal, but for specialist applications (e.g., involving strong acids or pharmaceuticals), other materials such as graphite, plastic and glass may be used a simple form of the shell and tube heat exchanger is double pipe heat exchanger.

1.4.2 Plate Heat Exchangers:

Plate heat exchangers are constructed of several thin, corrugated plates bundled together. Each pair of plates creates a channel through which one fluid can flow, and the pairs are stacked and attached—via bolting, brazing, or welding—such that a second passage is created between pairs through which the other fluid can flow. The standard plate design is also available with some variations, such as in plate fin or pillow plate heat exchangers. Plate fin exchangers employ fins or spacers between plates and allow for multiple flow configurations and more than two fluid streams to pass through the device. Pillow plate exchangers apply pressure to the plates to increase the heat transfer efficiency across the surface of the plate. Some of the other types available include plate and frame plate and shell and spiral plate heat exchanger

This has a major advantage over a conventional heat exchanger in that the fluids are exposed to a much larger surface area because the fluids are spread out over the plates. This facilitates the transfer of heat, and greatly increases the speed of the temperature change. Plate heat exchangers are now common and very small brazed versions are used in the hot-water sections of millions of combination boilers. The high heat transfer efficiency for such a small physical size has increased the domestic hot water (DHW) flow rate of combination boilers. The small plate heat exchanger has made a great impact in domestic heating and hot-water. Larger commercial versions use gaskets between the plates, whereas smaller versions tend to be brazed.

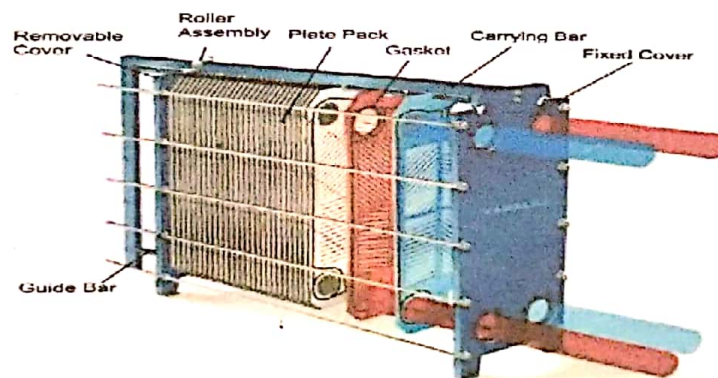

Figure 5 Plate Heat Exchanger

1.4.3 Double Pipe Heat Exchanger:

Double pipe heat exchanger is a form of shell and tube heat exchanger, which employ the simplest heat exchanger design and configuration which consists of two or more concentric, cylindrical pipes or tubes (one larger tube and one or more smaller tubes). As per the design of all shell and tube heat exchangers, one fluid flows through the smaller tube(s), and the other fluid flows around the smaller tube(s) within the larger tube. The design requirements of double pipe heat exchangers include characteristics from the recuperative and indirect contact types mentioned previously as the fluids remain separated and flow through their own channels throughout the heat transfer process. However, there is some flexibility in the design of double pipe heat exchangers, as they can be designed with co current or countercurrent flow arrangements and to be used modularly in series, parallel, or series-parallel configurations within a system. Double pipe heat exchangers can handle high pressures and temperatures well. When they are operating in true countercurrent, they can operate with a temperature cross, that is, where the cold side outlet temperature is higher than the hot side outlet temperature.



Figure 6 Double Pipe Heat Exchanger

1.4.3.1 Modes of Operation

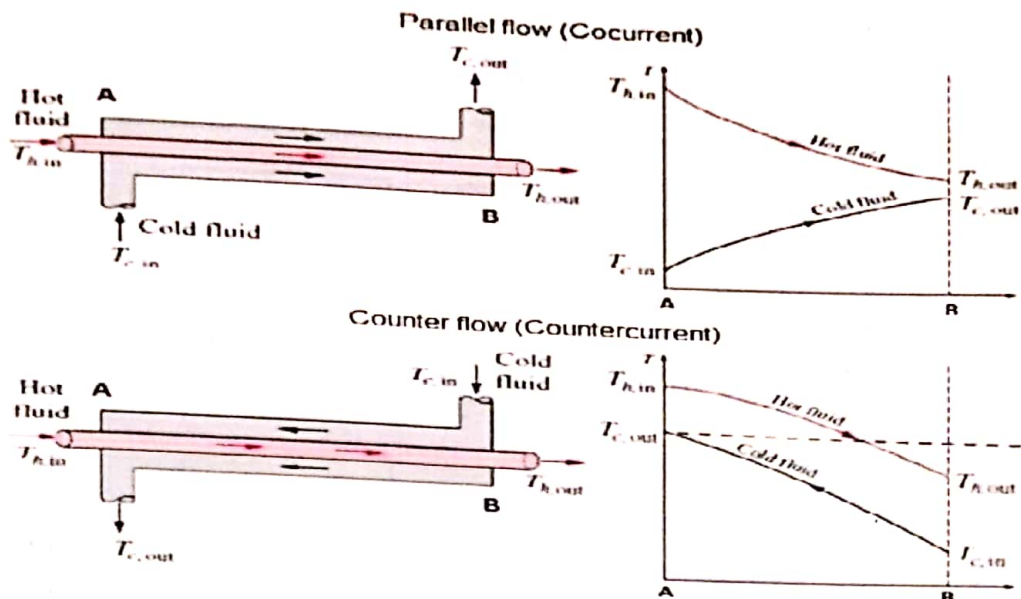

Figure 7 Modes Of Flow

Co-Current: The flow of the two streams is in the same direction.

Counter-Current: The flow of the two streams is in opposite directions. Countercurrent flow gives the highest heat transfer coefficient.

1.4.3.2 Advantages:

- Very simple to construct
- Very easy of operation
- U-type or hairpin constructions handle differential thermal expansions.

1.4.3.3 Disadvantages:

- The use of two single flow areas leads to relatively low flow rates and moderate temperature differences.
- Can't be used in handling dirty fluids. (Choking problem) (Used for only clean fluids)

1.5 Construction Method:

While in the previous section, heat exchangers were categorized based on the type of flow configuration employed, this section categorizes them based on their construction.

The construction characteristics by which these devices can be classified include:

- Recuperative vs. regenerative
- Direct vs. indirect
- Static vs. dynamic
- Types of components and materials employed

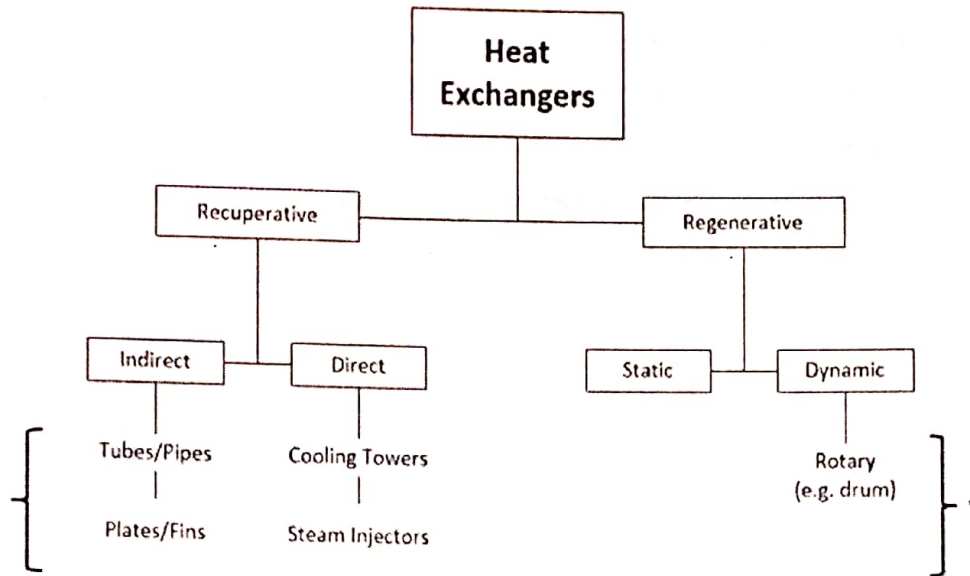

Figure 8 Heat Exchanger Classification By Construction

1.5.1.1 Recuperative vs. Regenerative:

Heat exchangers can be classified as recuperative heat exchangers and regenerative heat exchangers.

In recuperative heat exchangers (commonly called recuperates), each fluid simultaneously flows through its own channel within the heat exchanger. On the other hand, regenerative heat exchangers, also referred to as capacitive heat exchangers or regenerators, alternately allow warmer and cooler fluids to flow through the same channel. Both recuperators and regenerators can be further separated into different categories of exchangers, such as direct or indirect and static or dynamic, respectively. Of the two types indicated, recuperative heat exchangers are more commonly employed throughout industry.

1.5.1.2 Direct vs. Indirect:

Recuperative heat exchangers employ either direct contact or indirect contact transfer processes to exchange heat between fluids.

In direct contact heat exchangers, the fluids are not separated within the device and heat transfers from one fluid to another through direct contact. On the other hand, in indirect heat exchangers, the fluids remain separated from one another by thermally

conductive components, such as tubes or plates, throughout the heat transfer process. The components first receive heat from the warmer fluid as it flows through the heat exchanger, and then transfer the heat to the cooler fluid as it flows through. Some of the devices which employ direct contact transfer processes include cooling towers and steam injectors, while devices which employ indirect contact transfer processes include tubular or plate heat exchangers.

1.5.1.3 Static vs. Dynamic:

There are two main types of regenerative heat exchangers—static heat exchangers and dynamic heat exchangers. In static regenerators (also known as fixed bed regenerators), the heat exchanger material and components remain stationary as fluids flow through the device, while in dynamic regenerators the material and components move throughout the heat transfer process. Both types are at risk of cross-contamination between fluid streams, necessitating careful design considerations during manufacturing.

In one example of the static type, warmer fluid is run through one channel while cooler fluid runs through another for a fixed period at the end of which, using quick-operating valves, flow is reversed such that the two fluids switch channels. An example of the dynamic type typically employs a rotating, thermally conductive component (e.g., a drum) through which warmer and cooler fluids continuously flow—albeit in separate, sealed-off sections. As the component rotates, any given section alternately passes through the warmer steam and cooler streams, allowing for the component to absorb heat from the warmer fluid and transfer the heat to the cooler fluid as it passes through. Figure 10, below, depicts the heat transfer process within a rotary-type regenerator with a countercurrent flow configuration.

This section briefly describes some of the common types of heat exchangers explaining their respective function and mechanisms.

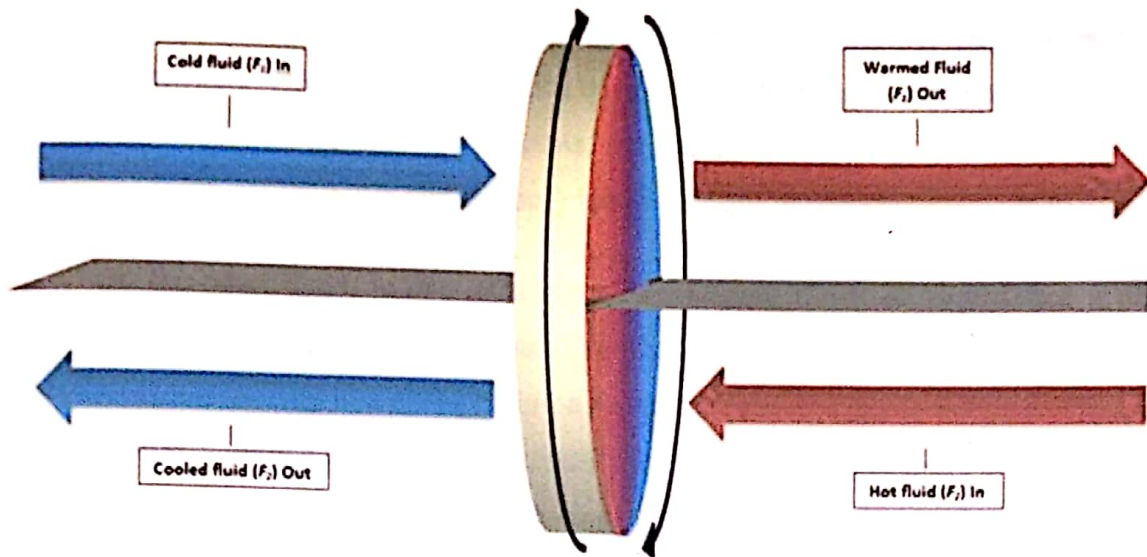

Figure 9 Heat Transfer In A Rotary-Type Regenerator

1.6 Heat Exchanger Components and Materials:

There are several types of components which can be employed in heat exchangers, as well as a wide range of materials used to construct them. The components and materials used depend on the type of heat exchanger and its intended application.

Some of the most common components used to construct heat exchangers include shells, tubes, spiral tubes (coils), plates, fins, and adiabatic wheels. Further detail on how these components function within a heat exchanger will be provided in the next section (see Types of Heat Exchangers).

While metals are highly suitable—and commonly used—for constructing heat exchangers due to their high thermal conductivity, as in the case of copper, titanium, and stainless steel heat exchangers, other materials, such as graphite, ceramics, composites, or plastics, may offer greater advantages depending on the requirements of the heat transfer application.

1.7 Heat Transfer Mechanism:

There are two types of heat transfer mechanisms employed by heat exchangers—single-phase or two-phase heat transfer.

In single-phase heat exchangers, the fluids do not undergo any phase change throughout the heat transfer process, meaning that both the warmer and cooler fluids remain in the same state of matter at which they entered the heat exchanger. For example, in water-to-water heat transfer applications, the warmer water loses heat which is then transferred to the cooler water and neither change to a gas or solid.

On the other hand, in two-phase heat exchangers, fluids do experience a phase change during the heat transfer process. The phase change can occur in either or both fluids involved resulting in a change from a liquid to a gas or a gas to a liquid. Typically, devices which employ a two-phase heat transfer mechanism require more complex design considerations than ones which employ a single-phase heat transfer mechanism. Some of the types of two-phase heat exchangers available include boilers, condensers, and evaporators.

1.8 Condensers, Evaporators, and Boilers:

Boilers, condensers, and evaporators are heat exchangers which employ a two-phase heat transfer mechanism. As mentioned previously, in two-phase heat exchangers one or more fluids undergo a phase change during the heat transfer process, either changing from a liquid to a gas or a gas to a liquid.

Condensers are heat exchanging devices which take heated gas or vapor and cool it to the point of condensation, changing the gas or vapor into a liquid. On the other hand, in evaporators and boilers, the heat transfer process changes the fluids from liquid form to gas or vapor form.

1.9 Other Heat Exchanger Variants:

Heat exchangers are employed in a variety of applications across a wide range of industries. Consequently, there are several variants of heat exchangers available, each suitable for the requirements and specifications of an application. Beyond the variants mentioned above, other types available include air cooled heat exchangers, fan cooled heat exchangers, and adiabatic wheel heat exchangers.

1.10 Heat exchanger Selection Consideration:

While there are a wide variety of heat exchangers available, the suitability of each type (and its design) in transferring heat between fluids is dependent on the specifications

and requirements of the application. Those factors largely determine the optimal design of the desired heat exchanger and influence the corresponding rating and sizing calculations.

Some of the factors that industry professionals should keep in mind when designing and choosing a heat exchanger include:

- The type of fluids, the fluid stream, and their properties
- The desired thermal outputs
- Size limitations
- Costs

1.10.1 Fluid Type, Stream and Properties:

The specific type of fluids—e.g., air, water, oil, etc.—involved and their physical, chemical, and thermal properties—e.g., phase, temperature, acidity or alkalinity, pressure and flow rate, etc.—help determine the flow configuration and construction best suited for that heat transfer application.

For example, if corrosive, high temperature, or high-pressure fluids are involved, the heat exchanger design must be able to withstand the high stress conditions throughout the heating or cooling process. One method of fulfilling these requirements is by choosing construction materials which hold the desired properties: graphite heat exchangers exhibit high thermal conductivity and corrosion resistance, ceramic heat exchangers can handle temperatures higher than many commonly used metals' melting points, and plastic heat exchangers offer a low-cost alternative which maintains a moderate degree of corrosion resistance and thermal conductivity. Another method is by choosing a design suited for the fluid properties: plate heat exchangers are capable of handling low to medium pressure fluids but at higher flow rates than other types of heat exchangers, and two-phase heat exchangers are necessary when handling fluids which require a phase change throughout the heat transfer process. Other fluid and fluid stream properties that industry professionals may keep in mind when choosing a heat exchanger include fluid viscosity, fouling characteristics, particulate matter content, and presence of water-soluble compounds.

1.10.2 Thermal Outputs:

The thermal output of a heat exchanger refers to the amount of heat transferred between fluids and the corresponding temperature change at the end of the heat transfer process. The transference of heat within the heat exchanger leads to a change of temperature in both fluids, lowering the temperature of one fluid as heat is removed and raising the temperature of the other fluid as heat is added. The desired thermal output and rate of heat transfer help determine the optimal type and design of heat exchanger as some heat exchanger designs offer greater heater transfer rates and can handle higher temperatures than other designs, albeit at a higher cost.

1.10.3 Size Limitations:

After choosing the optimal type and design of a heat exchanger, a common mistake is purchasing one that is too big for the given physical space. Oftentimes, it is more prudent to purchase a heat exchanging device in a size which leaves room for further expansion or addition, rather than choosing one which fully encompasses the space. For applications with limited space, such as in airplanes or automobiles, compact heat exchangers offer high heat transfer efficiencies in smaller, more lightweight solutions. Characterized by high heat transfer surface area to volume ratios, several variants of these heat exchanging devices are available, including compact plate heat exchangers. Typically, these devices feature ratios of $\geq 700 \text{ m}^2/\text{m}^3$ for gas-to-gas applications and $\geq 400 \text{ m}^2/\text{m}^3$ for liquid-to-gas applications.

1.10.4 Cost:

The cost of a heat exchanger includes not only the initial price of the equipment, but the installation, operational, and maintenance costs over the device's lifespan as well. While it is necessary to choose a heat exchanger which effectively fulfills the requirements of the applications, it is also important to keep in mind the overall costs of the chosen heat exchanger to better determine whether the device is worth the investment. For example, an initially expensive, but more durable heat exchanger may result in lower maintenance costs and, consequently, less overall spend over the courses of a few years, while a cheaper heat exchanger may be initially less expensive but require several repairs and replacements within the same period.

1.11 Design Optimization:

Designing the optimal heat exchanger for a given application (with specifications and requirements as indicated above) involves determining the temperature change of the fluids, the heat transfer coefficient, and the construction of the heat exchanger and relating them to the rate of heat transfer. The two main problems which arise in pursuing this objective are calculating the device's rating and sizing.

The rating refers to the calculation of the thermal effectiveness (i.e., efficiency) of a heat exchanger of a given design and size, including the rate of heat transfer, the amount of heat transferred between fluids and their corresponding temperature change, and the total pressure drop across the device. The sizing refers to the calculation of the required total dimensions of the heat exchanger (i.e., the surface area available for use in the heat transfer process), including the length, width, height, thickness, number of components, component geometries and arrangements, etc., for an application with given process specifications and requirements. The design characteristics of a heat exchanger—e.g., flow configuration, material, construction components and geometry, etc.—affect both the rating and sizing calculations. Ideally, the optimal heat exchanger design for an application finds a balance (with factors optimized as specified by the designer) between the rating and sizing which satisfies the process specifications and requirements at the minimum necessary cost.

1.12 Applications of Heat Exchangers:

Heat exchangers are devices used throughout industry for both heating and cooling processes. Several variants of heat exchangers are available and find application in a wide range of industries, including:

- ASME heat exchangers
- Automotive heat exchangers (typically as car radiators)
- Brewery heat exchangers
- Chemical heat exchangers
- Cryogenic heat exchangers
- Marine heat exchangers
- Power generation heat exchangers
- Refrigeration heat exchangers

Table 1, below, indicates some of the common industries and applications of the types of heat exchangers previously mentioned.

Table 1 Industries and Applications of Heat Exchangers by Type:

Type of Heat Exchanger	Common Industries and Applications
Shell and Tube	<ul style="list-style-type: none"> ➤ Oil refining ➤ Preheating ➤ Oil cooling ➤ Steam generation ➤ Boiler blowdown heat recovery ➤ Vapor recovery systems ➤ Industrial paint systems
Double Pipe	<ul style="list-style-type: none"> ➤ Industrial cooling processes ➤ Small heat transfer area requirements
Plate	<ul style="list-style-type: none"> ➤ Cryogenic ➤ Food processing ➤ Chemical processing ➤ Furnaces ➤ Closed loop to open loop water cooling
Condensers	<ul style="list-style-type: none"> ➤ Distillation and refinement processes ➤ Power plants ➤ Refrigeration ➤ HVAC ➤ Chemical processing
Evaporators/Boilers	<ul style="list-style-type: none"> ➤ Distillation and refinement processes ➤ Steam trains ➤ Refrigeration ➤ HVAC
Air Cooled/Fan Cooled	<ul style="list-style-type: none"> ➤ Limited access to cooling water

	<ul style="list-style-type: none"> ➤ Chemical plants and refineries ➤ Engines ➤ Power plants
Adiabatic Wheel	<ul style="list-style-type: none"> ➤ Chemical and petrochemical processing ➤ Petroleum refineries ➤ Food processing and pasteurization ➤ Power generation ➤ Cryogenics ➤ HVAC ➤ Aerospace
Compact	<ul style="list-style-type: none"> ➤ Limited space requirements (e.g., aircrafts and automobiles) ➤ Oil cooling ➤ Automotive ➤ Cryogenics ➤ Electronics cooling

1.13 Thermocouple:

A **thermocouple** is a sensor for measuring temperature. This sensor consists of two dissimilar metal wires, joined at one end, and connected to a thermocouple thermometer or other thermocouple-capable device at the other end. When properly configured, thermocouples can provide temperature measurements over wide range of temperatures. Thermocouples are known for their versatility as temperature sensors therefore commonly used on a wide range of applications - from an industrial usage thermocouple to a regular thermocouple found on utilities and regular appliances. Due to their wide range of models and technical specifications, it is extremely important to understand its basic structure, how it works, its ranges as to better determine what is the right type and material of thermocouple for your application.

1.13.1 Thermocouple Working Principle:

Thermocouple is based on three effects, discovered by Seebeck, Peltier and Thomson. They are as follows:

- **Seebeck Effect:** The Seebeck effect states that when two different or unlike metals are joined together at two junctions, an electromotive force (emf) is generated at the two junctions. The amount of emf generated is different for different combinations of the metals.
- **Peltier Effect:** As per the Peltier effect, when two dissimilar metals are joined together to form two junctions, emf is generated within the circuit due to the different temperature of the two junctions of the circuit.
- **Thomson Effect:** As per the Thomson effect, when two unlike metals are joined together forming two junctions, the potential exists within the circuit due to temperature gradient along the entire length of the conductors within the circuit.

In most of the cases the emf suggested by the Thomson effect is very small and it can be neglected by making proper selection of the metals. The Peltier effect plays a prominent role in the working principle of the thermocouple.

1.13.2 Thermocouple Working:

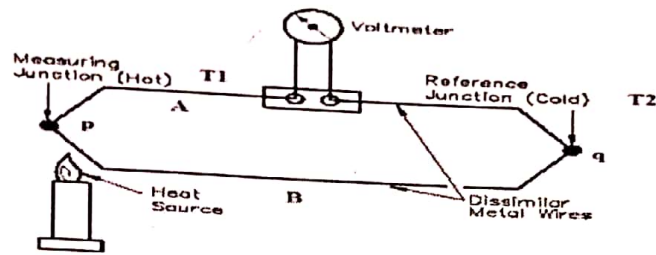

Thermocouple Circuit

Figure 10 Thermocouple Circuit

The general circuit for the working of thermocouple is shown in the figure 11 above. It comprises of two dissimilar metals, A and B. These are joined together to form two junctions, p and q, which are maintained at the temperatures T_1 and T_2 respectively.

Remember that the thermocouple cannot be formed if there are not two junctions. Since the two junctions are maintained at different temperatures the Peltier emf is generated within the circuit and it is the function of the temperatures of two junctions.

If the temperature of both the junctions is same, equal and opposite emf will be generated at both junctions and the net current flowing through the junction is zero. If the junctions are maintained at different temperatures, the emf's will not become zero and there will be a net current flowing through the circuit. The total emf flowing through this circuit depends on the metals used within the circuit as well as the temperature of the two junctions. The total emf or the current flowing through the circuit can be measured easily by the suitable device.

The device for measuring the current or emf is connected within the circuit of the thermocouple. It measures the amount of emf flowing through the circuit due to the two junctions of the two dissimilar metals maintained at different temperatures.

1.13.3 Types of Thermocouples:

Thermocouples are available in different combinations of metals or calibrations. The most common are the "Base Metal" thermocouples known as Types J, K, T, E and N.

There are also high temperature calibrations - also known as Noble Metal thermocouples -Types R, S, C:

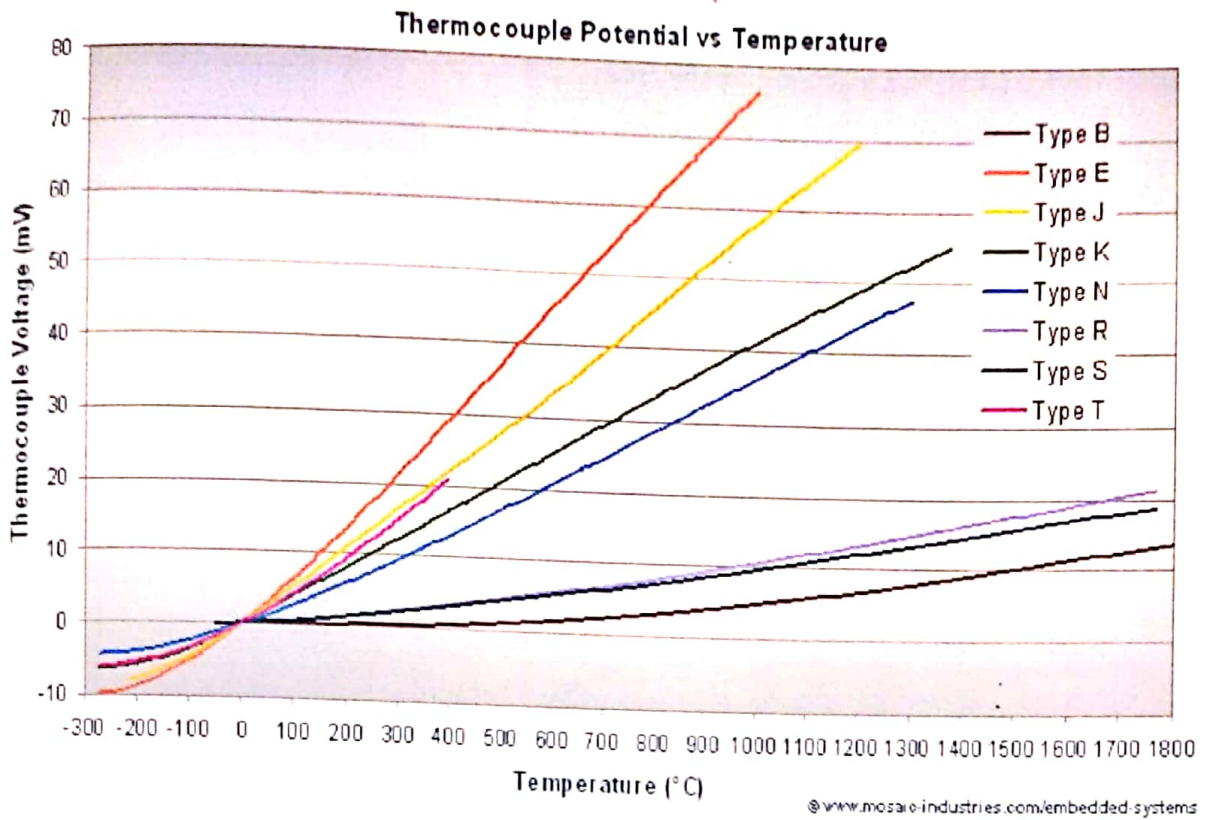

Figure 11 Thermocouple potential vs Temperature plot

Thermocouple sensitivity as thermocouple voltage vs temperature for common thermocouple types, using a cold junction at 0 °C.

CHAPTER-2

2 LITERATURE REVIEW

Kuruva Uma Mahesh et al. [1] on the study of developing heat exchangers which are highly efficient, compact, and cost effective. The objective of their work involved study of refinery process and applies phenomena of heat transfer to a double pipe heat exchanger. The geometry from their paper, it was depicted that the materials to be used should have a high mechanical resistance, corrosive resistance and high temperature withstanding capacity and the materials were selected on this basis. The objective of their study was based on design and thermal analysis of double pipe heat exchanger and the design was carried out based on the outlet temperature requirement of the cold fluid. With the help of computation fluid dynamics, the study and unsteady simulation was carried out for the designed heat exchanger and based on the simulation results, thermal analysis was carried out.

P.K. Swami et al. [2] formulated optimal design of the exchanger as a geometric programming with a single degree of difficulty. For yield problem the optimum values of inner/ outer pipe diameter and utility flow rate used for a double pipe heat exchanger of a given length, when a specified flow rate of process stream is to be treated for a given inlet to outlet temperature. They observed outlet temperature of the process stream is around 323 K which is well below the approachable temperature indicating the practicality of the solution. They found efficiency of the exchanger is around 63.6% which is reasonably high.

Timothy J. Rennie et al. [3] performed an experimental study of double pipe helical heat exchanger with parallel and counter flow configuration. Overall heat transfer coefficients were calculated and heat transfer coefficients in the inner tube and the annulus were determined using Wilson plots. They calculated a Nusselt numbers for the inner tube and the annulus. Heat transfer rates, however, are much higher in the counter flow configuration, due the increased log mean temperature difference.

Patil Amar.B. et al. [4] Their paper revealed the heat transfer characteristics, flow friction characteristics, of a horizontal tube-in-tube heat exchanger for single phase heat transfer with water as the working fluid. The material used for the construction of heat exchanger is copper, owing to its high thermal conductivity. The various techniques for achieving improved heat transfer are usually referred to as "heat transfer augmentation" or "heat transfer enhancement" and the heat exchanger provided with heat transfer enhancement techniques as "Augmented Heat Exchanger". The objective is to reduce as

many of the factors as possible capital cost, power cost, maintenance cost, space and weight, consistent with safety and reliability.

Rakesh C et al. [5] Present study deals with the performance analysis of existing double pipe heat exchanger. The actual performance analysis of a double pipe heat exchanger can be accurately determined only by operating the exchanger at different flow rates i.e. at nominal flow and +/- 10% of the nominal flow and different flow configurations (parallel and counter flow). The trials were carried out at different times on different days and the repeatability was checked. From this performance curves were plotted, and effectiveness of the heat exchanger is determined. Since the effectiveness of the installed setup is very close to the minimum requirement, the replacement of the heat exchanger has been designed theoretically (by models available in literature) to increase the margin of safety and examined the effects of various parameters such as effectiveness of the heat exchanger (ϵ), overall heat transfer coefficient (U), LMTD & pressure drop.

Kirti B.Zare et al. [6] Performed an experimental investigation on horizontal double pipe heat exchanger made from Galvanized iron tube with inner tube and outer tube. This heat exchanger uses various inserts inside tube to enhance heat transfer and hence increase the heat transfer coefficient. They have observed the horizontal double heat exchangers with different flow and their respective temperature profile for counter flow. These heat exchangers are different from the conventional heat exchangers such that they have large heat transfer surface area per unit volume.

C.K. Pardhi et al. [7] Their journal revealed various techniques for achieving improving heat transfer i.e.. "Heat transfer enhancement" and the heat exchanger provided with heat transfer enhancement techniques as "Augmented Heat Exchanger". Their objective is to reduce as many of the factors as possible: Capital Cost, Power Cost, Maintenance Cost, Space and Weight, Consistent with safety and reliability. Present work describes the principal techniques of industrial importance for augmentation of single-phase heat transfer with twisted tapes on the inner tubes. These twisted tapes should be used in heat exchanger when high heat transfer and pressure drop is of no significance.

K. Simhadri et al. [8] Their paper revealed about improving the heat exchanger performance by inserting a twisted sheet into the inner pipe. Their main objective was to

create turbulence in the hot fluid channel with the help of twisted sheet inserts so that an increase in the heat transfer coefficient can be identified. They conducted several experiments and the overall heat transfer coefficient value of double pipe heat exchanger without and with various twisted inserts of different twist ratios are compared. To obtain better effectiveness they considered counter flow and in addition to these twisted inserted sheets of different twist ratios are inserted in the hot fluid channel. This journal explained various merits and demerits of twisted sheets inside a double pipe heat exchanger and its various applications

CHAPTER-3

3 PROBLEMSTATEMENT

From the literature survey it is understood that various authors used expensive materials for making the experimental set up of a double pipe heat exchanger and it can be used for either parallel flow or counter flow. But in this project the double pipe heat exchanger which can be used for both parallel and counter flows is made with an economical cost which costs only 30% of the cost spent by the other people who have done the fabrication of it.

The experiment investigation has been reported under following headings

- Using economical and easily available materials
- Fabrication of double pipe heat exchanger
- Finding over all heat transfer coefficient

4 DESIGN AND FABRICATION

4.1 Design:

Reason for choosing 120cm effective length:

The effect of length on the average heat transfer from a tube to a fluid in turbulent flow inside it is studied for that condition where turbulence at the entrance to the heat transfer tube is fully developed. The analysis of the experimental data available shows that the factor S in the equation $h_{av} = h^* \left(\frac{1+SD}{L} \right)$ is not constant but varies with both $\frac{L}{D}$ and Re .

So, if the length is increasing average heat transfer coefficient will increase there by heat transfer rate will also increase according to the relation

$$Q = h A \Delta T \quad (Q \propto h)$$

Where

Q = Rate of heat transfer

A = Surface area

h = Convective heat transfer coefficient

ΔT = Temperature difference

Thickness reason:

As inner pipe thickness is less the heat transfer rate will increase according to the relation

$$Q = KA \left(\frac{dt}{dx} \right)$$

$$Q \propto \left(\frac{1}{dx} \right)$$

Therefore, if dx decreases then Q will increase

Where

Q = Rate of heat transfer

A = Area of cross section

K = thermal conductivity

$\frac{dt}{dx}$ = Temperature gradient

- inner pipe thickness is less for better conduction
- outer pipe thickness is more to reduce conduction through wall

Why These Materials?

Copper is having high thermal conductivity of 385 W/m²K. and CPVC behave like an insulator as well as outer pipe having very less thermal conductivity of 0.14 W/m²K

4.1.1 Dimensions:

DESCRIPTION	Material / VALUE
Material of inner pipe	Copper (inner dia 24.6mm, outerdia25.4mm)
Material of outer pipe	CPVC (inner dia 50.25mm, outer dia 50.8mm)
Effective length	120mm

4.2 Fabrication:

Inner copper pipe (1inch) is kept inside the outer CPVC pipe(2inch) by using 2-inch x 1-inch reducer. Cross joints are used for flow inlet and outlets of cooling water. CPVC (1 inch) pie is used for connection from the geyser to the inner copper pipe. Elbow is used at the bend from geyser to inner pipe.

Thermocouples are placed near the inlet and outlets for the temperature readings.

4.2.1 Components used in Fabrication:

4.2.1.1 T- Joint:

Tee joint used for providing four ways for the pipe inlets and outlets by providing another hole at the bottom of the Tee joint

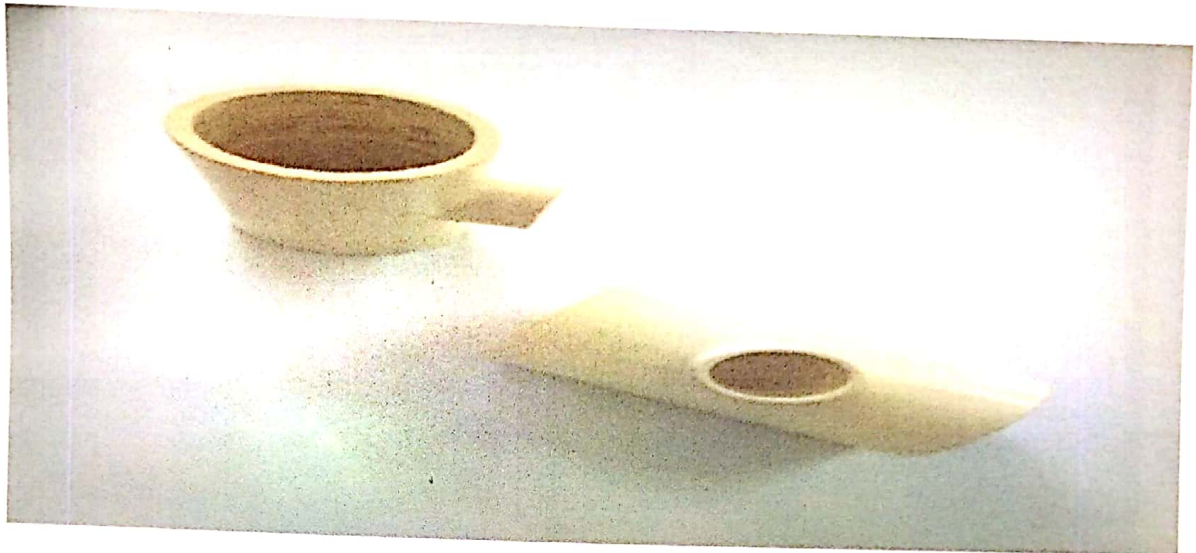

Figure 12 T-Joint

4.2.1.2 Ball Valves:

Ball valves of one-inch size are used for flow stoppage and to regulate the flow rate

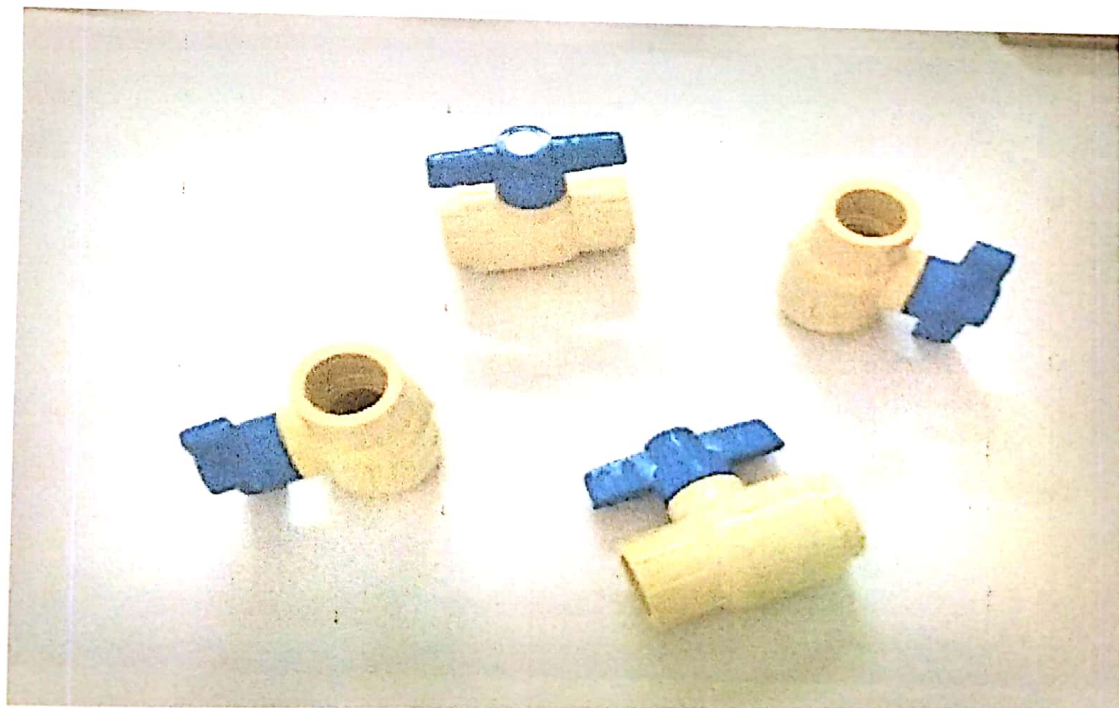

Figure 13 Ball Valve

4.2.1.3 Reducer:

Reducer of 2inch x 1 inch is used for joining 2inch outer pipe to 1-inch inner pipe

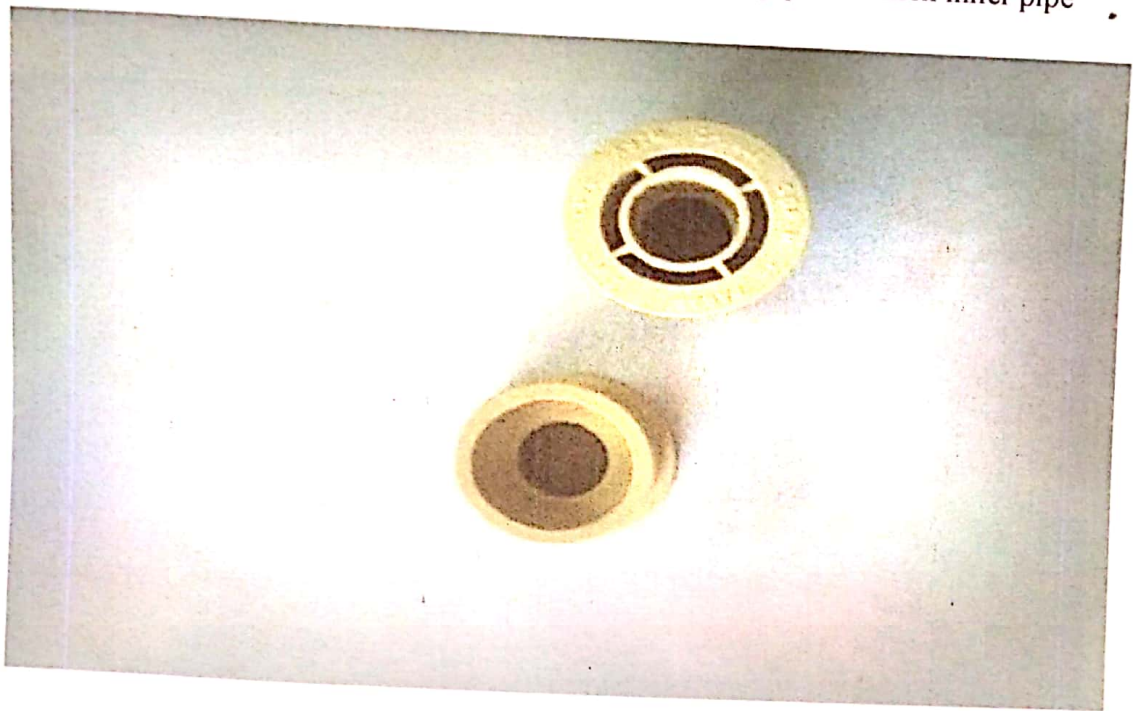

Figure 14 Reducer

4.2.1.4 Elbow Joint:

Elbow joint is used for joining flow from geyser pipe to the inner pipe



Figure 15 Elbow Joint

4.2.1.5 Thermocouple:

Thermocouple of K type having range of 1200°C is used for determining the inlet and outlet temperatures of hot water and cold water

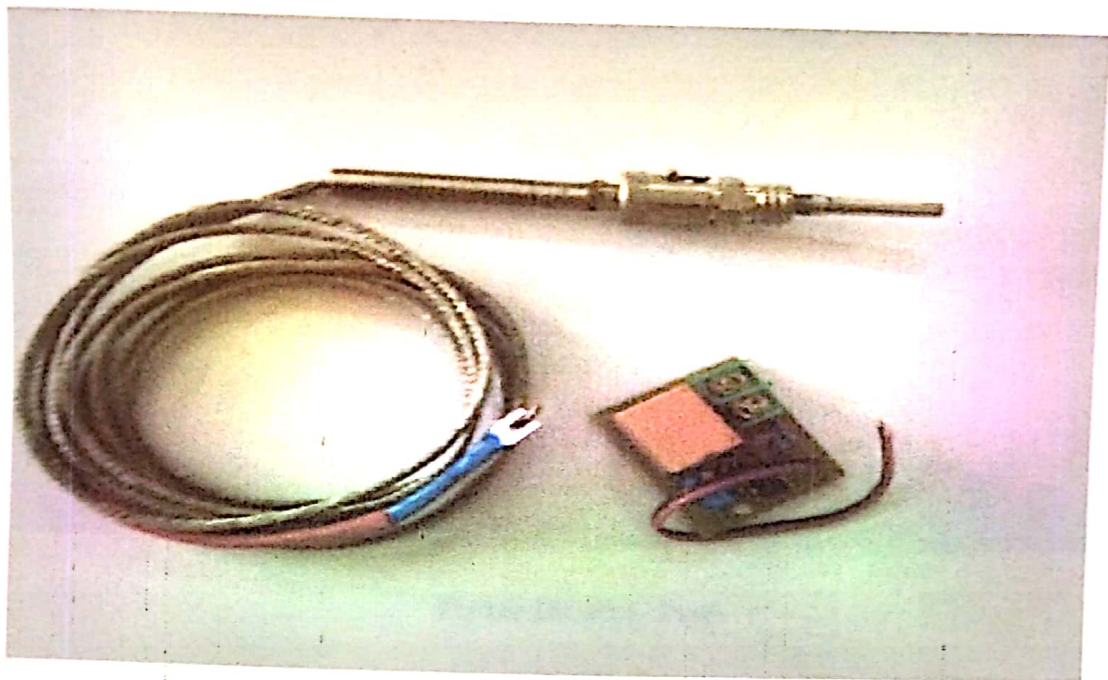

Figure 16 Thermocouple

4.2.1.6 CPVC Adhesive:

Astron CPVC adhesive is used for attaching tee joint with pipes and to make sure that no leak formation



Figure 17 CPVC Adhesive

4.2.1.7 Pipes:

Copper and CPVC pipes are used for making heat exchanger

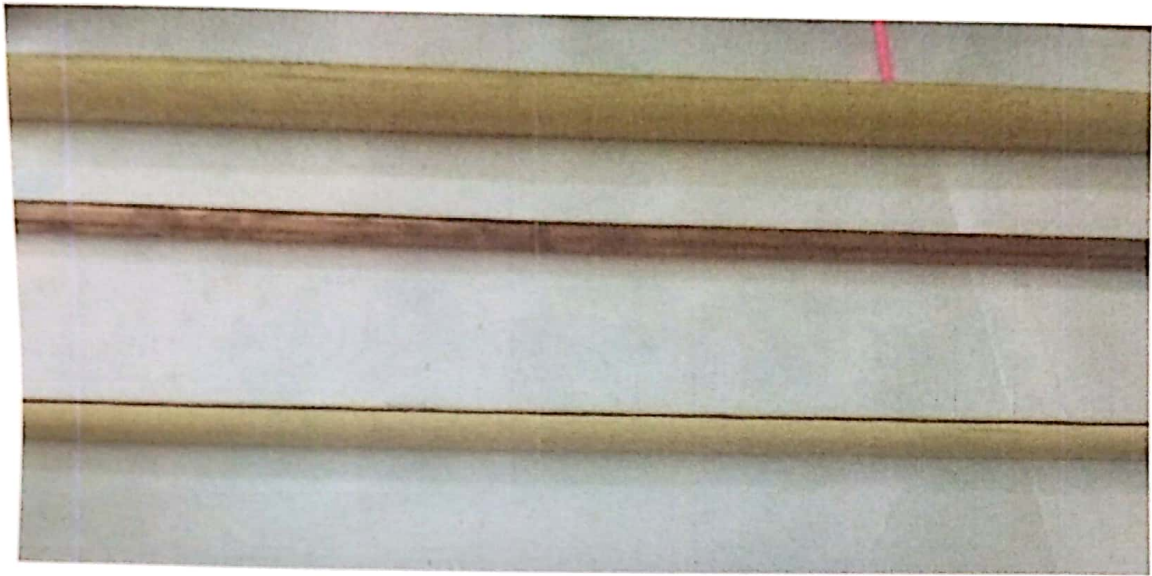

Figure 18 CPVC Pipes

4.2.2 Experimental Setup:



Figure 19 Experimental Set Up

CHAPTER-5

5 EXPERIMENT PROCEDURE

- Water supply is given to the geyser and switch of the geyser to be in ON position.
- Knob of the geyser is set to required inlet temperature of hot water.
- After attaining the required temperature, allow the hot water to pass through the inner copper pipe and simultaneously cold-water supply is given to the outer pipe.
- Parallel flow: only the cold-water supply is given in parallel flow direction and valves used for counter flow must be used in closed position.
- Counter flow: only the cold-water supply is given in counter flow direction and valves used for parallel flow must be used in closed position.
- Heat exchange takes place between hot water and the cold water.
- Readings should be taken until it reaches steady state.
- Calculations should be done

CHAPTER-6

6 OBSERVATIONS AND CALCULATIONS

Observations:

Table 2 Parallel Flow:

S.NO.	HOT WATER			Cold water		
	Flow rate(m_h) (Kg/sec)	Inlet temperature (T_{hi}) °C	Outlet temperature (T_{ho}) °C	Flow rate(m_c) (Kg/sec)	Inlet temperature (T_{ci}) °C	Outlet temperature (T_{co}) °C
1.	0.04081	45	45	0.03048	31	32
2.	0.04081	45	42	0.03048	31	35
3.	0.04081	45	39	0.03048	31	36
4.	0.04081	45	39	0.03048	31	37
5.	0.04081	45	39	0.03048	31	37

Last Readings Are The Steady State Readings.

Table 3 Counter Flow:

S.NO.	HOT WATER			COLD WATER		
	Flow rate(m_h) (Kg/hr)	Inlet temperature (T_{hi}) °C	Outlet temperature (T_{ho}) °C	Flow rate(m_c) (Kg/hr)	Inlet temperature (T_{ci}) °C	Outlet temperature (T_{co}) °C
1.	0.04081	45	43	0.03048	31	34
2.	0.04081	44	43	0.03048	31	34
3.	0.04081	45	41	0.03048	31	36
4.	0.04081	45	40	0.03048	31	37
5.	0.04081	45	38	0.03048	31	38
6.	0.04081	45	39	0.03048	31	41
7.	0.04081	45	39	0.03048	31	41

6.1 Calculation Of Heat Transfer Rate

q_h = Heat transfer rate from hot water

$$= m_h C_{ph}(T_{hi}-T_{ho}) \text{ KJ/sec}$$

q_c = Heat transfer rate to the cold water

$$= m_c C_{pc}(T_{co}-T_{ci}) \text{ KJ/sec.}$$

$$Q = \left(\frac{q_h + q_c}{2} \right) \text{ KJ/sec.}$$

LMTD: When heat capacities of both streams are constant and there is no phase change at constant pressure for streams that contain a single component: For countercurrent flow, the logarithmic mean temperature difference is given

LMTD-logarithmic mean temperature difference which can be calculated as per the following formula:

$$\text{LMTD} = \Delta T_m = \frac{(\Delta T_i - \Delta T_o)}{\ln\left(\frac{\Delta T_i}{\Delta T_o}\right)}$$

Where $\Delta T_i = T_{hi} - T_{ci}$ (for parallel flow)

$$= T_{hi} - T_{co} \text{ (for counter flow)}$$

$$\Delta T_o = T_{ho} - T_{co} \text{ (for parallel flow)}$$

$$= T_{ho} - T_{ci} \text{ (for counter flow)}$$

Note: In a special case of counter flow heat exchanger when the heat capacity rates C_c & C_h are equal, then $T_{ho} - T_{ci} = T_{hi} - T_{co}$ there by making $\Delta T_i = \Delta T_o$. In this case LMTD is of the form 0/0 and so unidentified. But it is obvious that ΔT_m is constant throughout the exchanger.

Hence, $\Delta T_m = \Delta T_i = \Delta T_o$

6.2 Overall Heat Transfer Coefficient:

The overall heat transfer coefficient is necessary in order to determine the heat transferred from the inner pipe to the outer pipe. The coefficient considers all the conductive and convective resistances (k and h

respectively) between fluids separated by the inner pipe and considers thermal resistances caused by fouling (rust, scaling, etc.) on both sides of the inner pipe.

Overall Heat Transfer Coefficient Can Be Calculated By Using:

$$Q = U A \Delta T_m$$

$$U = \left(\frac{Q}{A \Delta T_m} \right)$$

Calculated U_r based on $A_i = \pi d_i L$

U_o based on $A_o = \pi d_o L$

$$U = \left(\frac{U_i + U_o}{2} \right)$$

6.3 Parallel Flow

Where

$T_{hi} = 45$ Temperature of Hot water input °C

$T_{ho} = 39$ Temperature of Hot water output °C

$T_{ci} = 31$ Temperature of cold-water input °C

$T_{co} = 37$ Temperature of cold-water output °C

Inner diameter of copper $d_1 = 24.6$ mm

Outer diameter of copper $d_2 = 25.4$ mm

Length of the Heat Exchanger (L) = 1200 mm

Area of Inner Tube $A_i = \pi d_1 L = \pi * 24.6 * 1200 = 92739.81 \text{ mm}^2$

Area of Outer Tube $A_o = \pi d_2 L = \pi * 25.4 * 1200 = 95755.744 \text{ mm}^2$

Hot Water Flow Rate (m_h) = 0.04081 kg/sec

cold water Flow Rate (m_o) = 0.03048 kg/sec

for water $C_{ph} = C_{pc} = C_p = 4.18$ KJ/KgK

6.3.1 Heat Transfer Rate:

Q_h = Heat transfer rate from hot water

$$= m_h C_{ph} (T_{hi} - T_{ho}) \text{ KJ/sec}$$

$$= (0.040816)(4.187)(45-39)$$

$$= 1.02537 \text{ KJ/sec}$$

$$= 1025.37 \text{ J/sec}$$

Q_c = Heat Transfer rate to the cold water

$$= m_c C_{pc} (T_{co} - T_{ci}) \text{ KJ/sec}$$

$$= (0.03048) (4.187) (37-31)$$

$$= 0.7657 \text{ KJ/sec}$$

$$= 765.7 \text{ J/sec}$$

$$Q = (Q_h + Q_c)/2$$

$$= 895.525 \text{ W}$$

6.3.2 LMTD

logarithmic mean temperature difference which can be calculated as per the following

Formula:

$$LMTD = \Delta T_m = \left(\frac{\Delta T_1 - \Delta T_2}{\ln \left(\frac{\Delta T_1}{\Delta T_2} \right)} \right)$$

Where $\Delta T_1 = T_{hi} - T_{ci}$ (for parallel flow)

$$= 45 - 31$$

$$= 14 \text{ K}$$

$\Delta T_2 = T_{ho} - T_{co}$ (for parallel flow)

$$= 39 - 37$$

$$= 2 \text{ K}$$

$$\Delta T_m = \left(\frac{\Delta T_1 - \Delta T_2}{\ln \left(\frac{\Delta T_1}{\Delta T_2} \right)} \right)$$

$$= (14 - 2) / \ln(14/2)$$

$$= 6.1667 \text{ K}$$

6.3.3 Overall Heat Transfer Coefficient

$$Q=UA \Delta T_m$$

$$U=\left(\frac{q}{A \cdot \Delta T_m}\right) \text{ KJ/sec.mm}^2.\text{K}^\circ\text{C}$$

$$U_i=\left(\frac{Q}{A_i \Delta T_m}\right)$$

$$=1566 \text{ W/m}^2\text{K}$$

$$U_o=\left(\frac{Q}{A_o \Delta T_m}\right)$$

$$=1516.7 \text{ W/m}^2\text{K}$$

$$U=(U_i+U_o)/2$$

$$U=1541 \text{ W/m}^2\text{K}$$

6.4 Counter Flow

Where

$$T_{hi} = 45 \quad \text{Temperature of Hot water input } ^\circ\text{C}$$

$$T_{ho} = 38 \quad \text{Temperature of Hot water output } ^\circ\text{C}$$

$$T_{ci} = 31 \quad \text{Temperature of cold-water input } ^\circ\text{C}$$

$$T_{co} = 41 \quad \text{Temperature of cold-water output } ^\circ\text{C}$$

$$\text{Inner diameter of copper } d_1 = 24.6 \text{ mm}$$

$$\text{Outer diameter of copper } d_2 = 25.4 \text{ mm}$$

$$\text{Length of the Heat Exchanger (L)} = 1200 \text{ mm}$$

$$\text{Area of Inner Tube } A_i = \pi d_1 L = 92739.81 \text{ mm}^2$$

$$\text{Area of Outer Tube } A_o = \pi d_2 L = 95755.744 \text{ mm}^2$$

$$\text{Hot Water Flow Rate}(m_h) = 0.04081 \text{ kg/sec}$$

$$\text{cold water Flow Rate}(m_c) = 0.03048 \text{ kg/sec}$$

$$\text{for water } C_{ph} = C_{pc} = C_p = 4.18 \text{ KJ/KgK}$$

6.4.1 Heat Transfer Rate

Q_h = Heat transfer rate from hot water

$$= m_h C_{ph} (T_{hi} - T_{ho}) \text{ KJ/sec}$$

$$= (0.040816) * (4.187) * (45 - 39)$$

$$= 1.02537 \text{ KJ/sec}$$

$$= 1025.37 \text{ J/sec}$$

Q_c = Heat Transfer rate to the cold water

$$= m_c C_{pc} (T_{co} - T_{ci}) \text{ KJ/sec}$$

$$= (0.03048) * (4.187) * (37 - 31)$$

$$= 0.7657 \text{ KJ/sec}$$

$$= 765.7 \text{ J/sec}$$

$$Q = (Q_h + Q_c) / 2$$

$$= 895.525 \text{ W}$$

6.4.2 LMTD

logarithmic mean temperature difference which can be calculated as per the following

Formula:

$$LMTD = \Delta T_m = \left(\frac{\Delta T_i - \Delta T_o}{\ln \left(\frac{\Delta T_i}{\Delta T_o} \right)} \right)$$

Where $\Delta T_i = T_{hi} - T_{co}$ (for counter flow) = 4 K

$\Delta T_o = T_{ho} - T_{ci}$ (for counter flow) = 7 K

$$LMTD = \Delta T_m = \left(\frac{\Delta T_i - \Delta T_o}{\ln \left(\frac{\Delta T_i}{\Delta T_o} \right)} \right)$$

$$= \left(\frac{4 - 7}{\ln \left(\frac{4}{7} \right)} \right) = 5.3608 \text{ K}$$

6.4.3 Overall Heat Transfer Coefficient

$$Q=UA \Delta T_m$$

$$U=\left(\frac{q}{A \cdot \Delta T_m}\right) \text{ KJ/sec.mm}^2.\text{K} \square$$

$$U_i=\left(\frac{Q}{A_i \Delta T_m}\right)$$

$$=1801.28 \text{ W/m}^2\text{K}$$

$$U_o=\left(\frac{Q}{A_o \Delta T_m}\right)$$

$$=1791.258 \text{ W/m}^2\text{K}$$

$$U=(U_i+U_o)/2$$

$$U=1796.259 \text{ W/m}^2\text{K}$$

6.5 Precautions:

- Valves which must be opened, and which must be in closed state should be considered before starting the experiment.
- Reading after attaining steady only be used for calculations
- Care should be taken while measuring hot water at the outlet for flow rate

6.6 Result:

The overall heat transfer coefficient of the parallel and counter flow heat exchanger is

For parallel flow=1541W/m²K

For counter flow=1796.26W/m²K

CHAPTER-7

7 CONCLUSION

The complete design and fabrication of the parallel and counterflow heat exchanger was done. And the calculations of the double pipe heat exchanger have been done.

- From the study the following conclusions have been drawn:
- The overall heat transfer coefficient of the heat exchanger for parallel flow was found to be $U=1541\text{W/m}^2\text{K}$
- The overall heat transfer coefficient of the heat exchanger for counter flow was found to be $U=1796.26\text{W/m}^2\text{K}$
- From the above values it is concluded that the heat transfer in counter flow is more than parallel flow.

Scope of study

The scopes of this research are

1. To find out the overall heat transfer coefficient.
2. To replace double pipe heat exchangers of labs with economical one.

REFERENCES

- [1] Kuruva Uma Mahesh, K. Venugopal, Department of THERMAL, MLR Institute of Technology, Ranga Reddy, Telangana, India - International Journal of Professional Engineering Studies |Vol V| Issue 2| July- 2015.
- [2] P.K. Swamee, Department of Civil Engineering, Indian Institute of Technology, Roorkee, India - International Journal of Heat and Mass Transfer | Volume 51|, |Issues 9–10|, May - 2008, Pages 2260-2266.
- [3] Timothy J. Rennie, Vijay G.S Raghavan, Department of Bioresource Engineering, McGill University, 21 111 Lakeshore Rd., Sainte Anne-de-Bellevue, QC, Canada H9X 3V9 - Elsevier Journal, Applied Thermal Engineering |Volume 26| Issues 11–12| August 2006, Pages 1266-1273.
- [4] Patil Amar. B, Dange H. M, Department of Mechanical Technology Kit's College of TECHNOLOGY, Maharashtra, India IJRST – International Journal for Innovative Research in Science and Technology |Vol:1| Issue 5|October 2014| ISSN (online): 2349-6010.
- [5] Rakesh C, CharanNallode, Assistant Professor, Department of Mechanical Engineering, New Horizon College of Engineering, Bangalore, India IJRST - International Journal of Innovative Research in Science, Engineering and Technology |Vol. 6|Issue 7| July 2017.
- [6] Kirti B. Zara, Dipika Kanchan, Nupur Patel, Chemical Engineering, D.Y. Patil Institute of Engineering, Management and Research, Akurdi, Pune, India IJSTM – International Journal of Science Technology and Management |Vol:5| Issue 12| December 2016.
- [7] C.K. Pardhi, Prasanth Baredar, Assistant Professor Department of Mechanical Engineering SISTec-R Bhopal, M.P., India, Associate Professor Department of Energy, MANIT Bhopal, M.P., India – [IJESAT] International Journal of Engineering Science and Advanced Technology |Volume-2| Issue-4, 881 – 885.
- [8] K. Simhadri, G.V. DMohan and P. Sai Chaitanya, Department of Mechanical Engineering, GMRIT, Rajam, India - IOSR Journal of Mechanical and Civil Engineering (IOSR-JMCE) |Vol:12| Issue 2 Ver. VI| Mar – Apr. 2015), PP 115-12