

Study on Effectiveness of Tungsten Carbide Tools Using Taguchi and Anova

A Project report submitted in partial fulfillment of the requirements

for the award of the degree of

BACHELOR OF TECHNOLOGY

In

MECHANICAL ENGINEERING

By

V. Raghuram (318126520L32)

G. Lakshmi Narayana (318126520L33)

L. Abhilash varma (317126520147)

M. Teja (317126520150)

Shaik Kareem (317126520169)

Under the esteemed guidance of

Mr. J.Mahesh M.Tech (Ph.D)

Assistant Professor



DEPARTMENT OF MECHANICAL ENGINEERING

ANIL NEERUKONDA INSTITUTE OF TECHNOLOGY & SCIENCES (A)

**(Approved by AICTE, Permanently Affiliated to Andhra University, Accredited by NBA and
NAAC- 'A' Grade)**

Sangivalasa, Bheemunipatnam Mandal

Visakhapatnam (District) – 531162

ANIL NEERUKONDA INSTITUTE OF TECHNOLOGY & SCIENCES (A)

(Affiliated to Andhra University, Approved by AICTE, Accredited by NBA & NAAC with A grade)
SANGIVALASA, VISAKHAPATNAM (District) – 531162



CERTIFICATE

This is to certify that the Project Report entitled “**STUDY ON EFFECTIVENESS OF TUGSTEN CARBIDE TOOLS USING TAGUCHI AND ANOVA**” being submitted by VEMPADAPU RAGHURAM (318126520L32), GUDIVADA LAKSHMI NARAYANA (318126520L33), LANKE ABHILASH VARMA (317126520147), MALLAVARAPU TEJA (317126520150), SHAIK KAREEM (317126520169) in partial fulfillments for the award of degree of **BACHELOR OF TECHNOLOGY** in **MECHANICAL ENGINEERING**, ANITS. It is the work of bona-fide, carried out under the guidance and supervision of **MR.J.MAHESH**, Assistant Professor, Department Of Mechanical Engineering, ANITS during the academic year of 2017-2021.

PROJECT GUIDE

Maresh

(MR.J.MAHESH)
Assistant Professor
Mechanical Engineering Department
ANITS, Visakhapatnam.

Approved By

HEAD OF THE DEPARTMENT

(Signature)

(Dr. B. Naga Raju)
Head of the Department
Mechanical Engineering Department
ANITS, Visakhapatnam.

PROFESSOR & HEAD
Department of Mechanical Engineering
ANIL NEERUKONDA INSTITUTE OF TECHNOLOGY & SCIENCES
Sangivalasa-531 162 VISAKHAPATNAM Dist. A.P.

DECLARATION

We, the undersigned, hereby declare that this “**Thesis**” under the title of “**Study on Effectiveness of Tungsten Carbide Tools Using Taguchi and Anova**” submitted by me for the award of Degree of “**Bachelor of Technology**” in Mechanical Engineering at ANIL NEERUKONDA INSTITUTE OF TECHNOLOGY & SCIENCES (A), Visakhapatnam, is a record of original research work carried out by us. This work has not been submitted to any University or Institution in India or abroad, for the award of any degree

TEAM MEMBERS

V. Raghuram **318126520L32**

G. Lakshmi Narayana **318126520L33**

L. Abhilash varma **317126520147**

M. Teja **317126520150**

Shaik Kareem **317126520169**

ACKNOWLEDGMENTS

At the outset, we thank **Dr. T. V. HANUMANTHA RAO**, Professor & Principal, ANITS, for granting permission to do our project “**Study on Effectiveness of Tungsten Carbide Tools Using Taguchi and Anova**”. We also thank him for his constant encouragement and support for this project.

We express our sincere thanks to **Dr. B. NAGA RAJU**, Professor & Head, Department of Mechanical Engineering for his valuable guidance, suggestions and comprehensive assistance for the project work.

We also express my deep gratitude to my project guide, **Mr.J. Mahesh M.Tech (Ph.D)**, Assistant Professor, Department of Mechanical Engineering, under whose valuable guidance, we were able to complete our project smoothly.

Our sincere regards to all other staff members who helped us directly and indirectly in handling this project work progressively towards success.

TEAM MEMBERS

V. Raghuram	318126520L32
G. Lakshmi Narayana	318126520L33
L. Abhilash varma	317126520147
M. Teja	317126520150
Shaik Kareem	317126520169

CONTENTS

	Page No.
ABSTRACT	i
LIST OF FIGURES	ii
LIST OF TABLES	iii
NOMENCLATURE	iv
CHAPTER-1 INTRODUCTION	1-13
1.1 Single Point Cutting Tool	2
1.2 Cutting Factors in Turning	3
1.2.1 Speed	3
1.2.2 Feed	4
1.2.3 Depth of Cut	4
1.3 Tool Geometry	4
1.3.1 Flank	4
1.3.2 Face	5
1.3.3 Back rake angle	5
1.3.4 Side rake angle	5
1.3.5 Side cutting edge angle	5
1.3.6 End cutting edge angle	5
1.3.7 Side relief angle	5
1.3.8 End relief angle	5
1.3.9 Nose radius	5
1.3.10 Lead angle	6

1.4 Recent trends in manufacturing by machining	6
1.5 Significance of Metal cutting	7
1.6 Theory of Metal cutting	7
1.7 Chronological Development of cutting tools	8
1.8 Coatings	9
1.8.1 Types of coating Technology	10
1.8.2 CVD	10
1.8.3 How does CVD Works	10
1.8.4 PVD	11
1.8.5 Advantages of CVD coated carbides	11
1.9 Types of Coating	11
1.9.1 Single layer coating	11
1.9.2 Multi-layer coatings	11
1.9.3 Why TiN	12
1.10 Tool wear	12
CHAPTER-2 LITERATURE REVIEW	14-23
CHAPTER-3 METHODOLOGY	24-28
3.1 Taguchi Method	25
3.2 Analysis of Variance	27
CHAPTER-4 EXPERIMENTAL DETAILS	29-34
4.1 Selection of Work Material	30
4.2 Selection of the Process Parameters and Their Levels	31
4.3 Selection of Orthogonal Array	31
4.4 Selection of Tools	33

CHAPTER-5 RESULTS AND DISCUSSIONS	35-42
5.1 Experimental Results	36
5.2 Taguchi and ANOVA analysis of MRR	37
5.3 Regression Model and Residual plots for MRR	39
5.3.1 Regression equation for MRR	39
5.4 Taguchi and ANOVA analysis of Ra	39
5.5 Regression Model and Residual plots for Ra	41
5.5.1 Regression equation for Ra	41
CHAPTER-6 CONCLUSIONS	43-44
CHAPTER-7 REFERENCES	45-50

ABSTRACT

The longer life of the cutting tool depends on various factors like machine tools used, cutting conditions, work piece material hardness etc. In the present work an experimental investigation has been made to study the influence of cutting tools over multiple performance characteristics. The experiments were performed on SS316 which has good machinability and corrosion resistance. Taguchi's standard L18 OA has been selected and the experimental responses obtained were analysed using taguchi method followed by Analysis of variance. The results revealed that depth of cut and feed are the most influencing factors for material removal rate and surface roughness respectively.

LIST OF FIGURES	Pg No
Figure 1.1 Nomenclature of a Single Point Tool	2
Figure 1.2 Diagram of the Machining Process	2
Figure 1.3 Cutting Angles	3
Figure 1.4 Tool Geometry	4
Figure 4.1 SS316 Material	30
Figure 4.2 Non- Coated Tool	33
Figure 4.3 Coated Tool	33
Figure 4.4 CNC Machine	33
Figure 4.5 Machined workpieces	34
Figure 4.6 SJ-210 Roughness Tester	34
Figure 5.1 Main Effects Plots For Means of MRR	38
Figure 5.2 Residual plots for MRR	39
Figure 5.3 Main Effects Plots For Means of Ra	40
Figure 5.4 Residual plots for Ra	42

LIST OF TABLES

Pg No

Table 4.1 Chemical Composition of SS316	30
Table 4.2 Mechanical Properties of SS316	30
Table 4.3 Process Parameters and Their Levels	31
Table 4.4 Taguchi L18 Orthogonal Array	32
Table 5.1 Experimental Results	36
Table 5.2 Response Table for Means of MRR	37
Table 5.3 Analysis of Variance for MRR	38
Table 5.4 Response Table for Means of Ra	40
Table 5.5 Analysis of Variance for Ra	41

NOMENCLATURE

v	Cutting Speed, Rpm
f	Feed, mm/rev
d	Depth of Cut, mm
MRR	Material Removal Rate, cm ³ /sec
R _a	Arithmetic Surface Roughness Average, μm
CNC	Computerized Numerical Control
DOE	Design of Experiments
OA	Orthogonal Array
S/N	Signal-to-Noise Ratio
ANOVA	Analysis of Variance
DF	Degree of Freedom
SS	Sum of Squares
MS	Mean Square
F	Variance Ratio
P	Probability of Significance

CHAPTER-1

INTRODUCTION

Turning is one of the major machining processes which includes metal cutting as removal of metal chips in order to get finished product of desired shape, size and surface roughness.

1.1. Single Point Cutting Tool

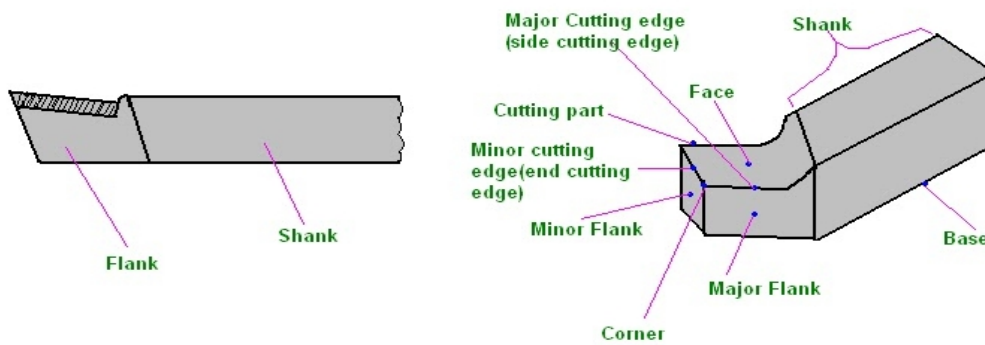

Fig. 1.1. Nomenclature of a Single Point Cutting Tool

Single point cutting tools have one principal cutting edge which is mainly used for cutting. These tools are used for turning, boring, planing etc. used in machines like lathe, boring and shaping machines. Single point cutting tools contain following parts: - shank (this is the main body of the tool), flank (which is adjacent below the cutting edge), face (the surface upon which chip slides), nose radius (it is the point where cutting edge intersects with side cutting edge). The schematic diagram of single point cutting tool is shown in Fig. 1.1.

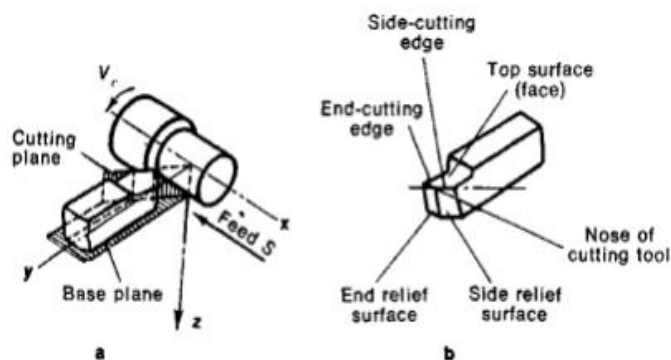

Fig. 1.2 Diagram of The Machining Process

The angle between the side relief face of the tool and machining plane is called side relief angle α . The relief angle depends upon rate of feed parameter, if feed increases, then relief angle increases in order to avoid friction between relief surface and cutting edge. The angle between the top and side relief surface of the tool is known as lip angle β . The angle

between the plane perpendicular to the cutting plane and the top surface of the tool is known as side rake angle γ . The mechanism of turning process is shown in Fig. 1.2.

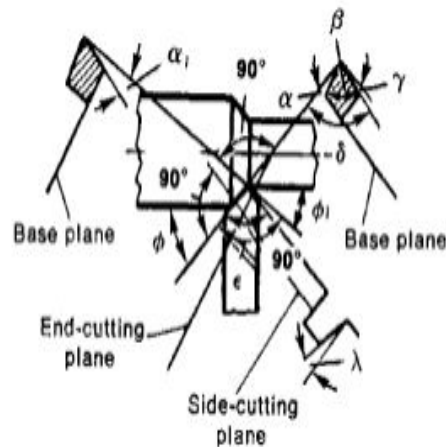

Fig. 1.3 Cutting Angles

Larger rake angles facilitate easier formation of chip in machining, but it decreases cutting force (less power consumption). For hard material, tool with small rake angle is always used. Finally, it can be observed that rake angle depends upon physical and mechanical properties of work-piece material. The cutting angles which are used for machining shown in Fig. 1.3 with projected point of view. Turning is the removal of metal from the outer diameter of a rotating cylindrical work piece. Turning is used to reduce the diameter of the work piece, usually to a specified dimension, and to produce a smooth finish on the metal can be defined as the machining of an external surface:

- With the work piece rotating
- With a single-point cutting tool, and
- With the cutting tool feeding parallel to the axis of the work piece and at a
- Distance that will remove the outer surface of the work.

1.2. Cutting Factors in Turning

The primary factors in any basic turning operation are speed, feed, and depth of cut. Other factors such as kind of material and type of tool have a large influence, of course, but these three are the ones the operator can change by adjusting the controls.

1.2.1. Speed

Speed refers to the spindle and the work piece. When it is stated in rpm, it tells their rotating speed. But the important feature for a particular turning operation is the surface speed that is the speed at which the work piece material is moving past the cutting tool. It is simply the product of the rotating speed times the circumference of the work piece before the

cut is started. It is expressed in meter per minute (m/min), and it refers only to the work piece. Every different diameter on a work piece will have a different cutting speed, even though the rotating speed remains the same.

$$v = 3.14DN/1000 \text{ (m/min)}$$

Here, v is the cutting speed in turning; D is the initial diameter of the work piece in mm.

1.2.2. Feed

Feed refers to the cutting tool and it is the rate at which the tool advances along its cutting path. In most of power-fed lathes, the feed rate is directly related to the spindle speed and is expressed in mm (of tool advance) per revolution (of the spindle), or mm/rev.

1.2.3. Depth of Cut

Depth of cut is the thickness of the layer being removed (in a single pass) from the work piece or the distance from the uncut surface of the work to the cut surface, expressed in mm. It is important to note that the diameter of the work piece is reduced by two times the depth of cut because this layer is being removed from both sides of the work piece.

1.3. Tool Geometry

For cutting tools, geometry shown in fig 1.4 depends on the properties of the tool material and the work material. For single point tools, the most important angles are the rake angles and the end and side relief angle.

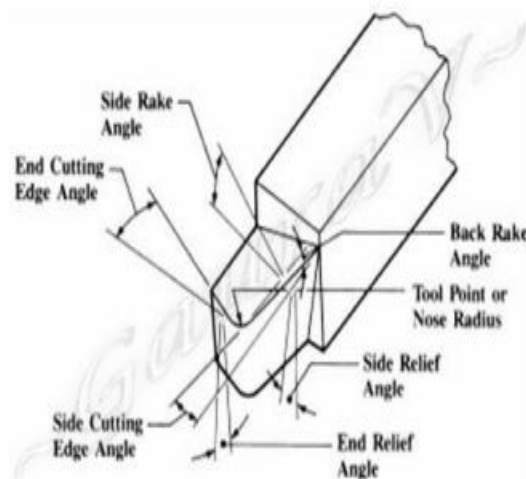

Figure. 1.4 Tool Geometry

1.3.1. Flank

A flat surface of a single-point tool that is adjacent to the face of the tool. During turning, the side flank faces the direction that the tool is fed into the work piece. At the end flank passes over the newly machined surface.

1.3.2. Face

The flat surface of a single point tool through which, the work piece rotates during turning operation is called the face of tool. On a typical turning setup, the face of the tool is positioned upwards.

1.3.3. Back rake angle

If viewed from the side facing the end of the work piece, it is the angle formed by the face of the tool, and a line parallel to the base. A positive back rake angle tilts the tool face back, and a negative angle tilts it forward and up.

1.3.4. Side rake angle

If viewed behind the tool down the length of the tool holder, it is the angle formed by the face of the tool and the centerline of the work piece. A positive side rake angle tilts the tool face down toward the floor, and a negative angle tilts the face up and toward the work piece.

1.3.5. Side cutting edge angle

If viewed from above looking down on the cutting tool, it is the angle formed by the side flank of the tool and a line perpendicular to the work piece centerline. A positive side cutting edge angle moves the side flank into the cut, and a negative angle moves the side flank out of the cut.

1.3.6. End cutting edge angle

If viewed from above looking down on the cutting tool, the angle formed by the end flank of the tool and a line parallel to the work piece centerline is called end cutting edge angle. Increasing the end cutting edge angle tilts the far end of the cutting edge away from the work piece.

1.3.7. Side relief angle

If viewed behind the tool down the length of the tool holder, the angle formed by the side flank of the tool and a vertical line down to the floor is called side relief angle. Increasing the side relief angle tilts the side flank away from the work piece.

1.3.8. End relief angle

If viewed from the side facing the end of the work piece, the angle formed by the end flank of the tool and a vertical line down to the floor is named as end relief angle. Increasing the end relief angle tilts the end flank away from the work piece.

1.3.9. Nose radius

It is the rounded tip on the cutting edge of a single point tool. A sharp point of the cutting tool is created by a zero degree nose radius.

1.3.10. Lead angle

Lead angle is the common name for the side cutting edge angle. If a tool holder is built with dimensions that shift the angle of an insert, the lead angle takes this change into consideration.

1.4. Recent trends in manufacturing by machining

The recent developments in science and technology has put tremendous pressure on manufacturing industries. The manufacturing industries are trying to decrease the cutting costs, increase the quality of the machined parts and machine more difficult materials. Machining efficiency is improved by reducing the machining time with high speed machining. When cutting ferrous and hard to machine materials such as steels, cast iron and super alloys, softening temperature and the chemical stability of the tool material limits the cutting speed. The productivity enhancement of manufacturing processes imposes the acceleration of the design and evolution of improved cutting tools with respect to the achievement of a superior tribological attainment and wear-resistance. Because of the highly nonlinear nature of metal cutting and the complex coupling between deformation and temperature fields, a complete understanding of the mechanics of metal cutting is still lacking and is thus the topic of great deal of current research. High speed machining has been the main objective of the Mechanical Engineering through ages. The trend to increase productivity has been the instrumental in invention of newer and newer cutting tools with respect to material and designs. High speed machining is not associated with increased productivity and better surface finish rather associated with a great amount of heat generation. Where the power requirement rises since large amount of cutting force is involved. Finish hard turning is a new machining process that enables manufacturers to machine hardened materials to their finish part quality without the aid of grinding. Hard turning with multilayer coated carbide tool has several benefits over grinding process such as, reduction of processing costs, increased productivities and improved material properties. This process enables manufacturers to increase product quality and efficiency, while decreasing the cost and processing time. Hard turning is also very attractive to manufacturers because this process is possible without the use of cutting fluid or other lubricants. Dry cutting is beneficial because of the elimination of the cost of the cutting fluid as well as the high cost of fluid disposal. The increasing need to boost productivity, to machine more difficult material and to improve quality in high volume by the manufacturing industry has been the driving force behind the development of cutting tool materials. One important aspect that is being vigorously researched and developed is the hard coating for cutting tools. These hard coatings are thin films that range from one layer to hundreds of layers and have thickness that range from few nanometers to few millimeters. These hard coatings have been proven to increase the tool life by as much as 10 folds through slowing down the wear phenomenon of the cutting tools. This increase in tool life allows for less frequent tool changes, therefore increasing the batch sizes that could be manufactured and in turn, not only reducing manufacturing cost, but also reducing the setup time as well as the setup cost. In addition to increasing the tool life, hard coating deposited on cutting tools allows for improved and more consistent surface roughness of the machined work piece. The surface roughness of the machined work piece changes as the geometry of the cutting tool

changes due to wear, and slowing down the wear process means more consistency and better surface finish.

Machining efficiency is improved by reducing the machining time with high speed machining. When cutting ferrous and hard to machine materials such as steels, cast iron and super alloys, softening temperature and the chemical stability of the tool material limits the cutting speed. Therefore, it is necessary for tool materials to possess good high-temperature, mechanical properties and sufficient inertness. While many ceramic materials such as TiC, Al₂O₃ and TiN possess high temperature strength, they have lower fracture toughness than that of conventional tool materials such as high-speed steels and cemented tungsten carbides. The machining of hard and chemically reactive materials at higher speeds is improved by depositing single and multi layer coatings on conventional tool materials to combine the beneficial properties of ceramics and traditional tool materials. The majority of cutting tools in use today employ chemical vapour deposition (CVD) or physical vapour deposition (PVD) hard coatings. The high hardness, wear resistance and chemical stability of these coatings offer proven benefits in terms of tool life and machining performance. The first technique is the CVD. This method deposits thin films on the cutting tools through various chemical reactions. Most tool coatings were traditionally deposited using the CVD technique until the recent development of PVD. This method deposits thin films on the cutting tools through physical techniques, mainly sputtering and evaporation. Coated hard metals have brought about tremendous increase in productivity since their introduction. Since then coatings have also been applied to high speed steel and especially to HSS drills. Coatings are diffusion barriers ,they prevent the interaction between chip formed during the machining and the cutting material itself. The compounds which make up the coatings used are extremely hard and so they are very abrasion resistant. Typical constituents of coating are Titanium Carbide(TiC), Titanium Nitride (TiN), Titanium Carbonitride (TiCN) and alumina (Al₂O₃).

1.5. Significance of Metal Cutting

Metal cutting is the removal of metal from work piece in the form of chips in order to obtain a finished product with desired size, shape and surface finish. In virtually all producing sectors for example automobiles, railways, shipbuilding, aircraft manufacture, home appliance , consumer electronics and construction industries etc one finds large shops with many thousands of machining .The cost of machining amounts to more than 15% of to value of the all manufactured products in all industrial countries. Of all the processes used to shape metals, in metal cutting the conditions of operation can be varied to a greater extent to improve the quality and the rate of producing with a reduced cost.

1.6. Theory of Metal Cutting

Metal cutting process forms the basis of the engineering industry and is involved either directly or indirectly in the manufacture of nearly every product of our modern civilization. The cutting tool is one of the important elements in realizing the full potential out of any metal cutting operation. Over the years the demands of economic competition have motivated a lot of research in the field of metal cutting leading to the evolution of new tool materials of

remarkable performance and vast potential for an impressive increase in productivity. As manufacturers continually seek and apply new materials for products that are lighter and stronger and therefore more efficient employing that cutting tools must be so developed that can machine new materials at the highest possible productivity.

The main properties which any cutting material must possess in order to carry out its function are:

- Hardness to overcome wearing action.
- Hot strength to overcome the heat involved
- Sufficient toughness to withstand vibration

In general, increasing hardness brings with it a reduction in toughness and so those materials in the higher hardness region of the list will fail by breakage if used for heavy cuts, particularly with work pieces which have holes or slots in them which give rise to interruption in the cut.

The properties that a tool material must possess are as follows:

- Capacity to retain form stability at elevated temperatures during high cutting speeds.
- Resistance to diffusion
 - High resistance to brittle fracture
 - Resistance to thermal and mechanical shock
- Low Cost and ease of fabrication

The cutting tools must be made of materials capable of withstanding

- High stresses (High strength and wear resistant)
- High temperature (high hot hardness)
- Shock generated during chip formation (tough)

In addition to this the material should have the following properties

- Chemical stability
- Anti welding and anti diffusivity
- Thermal conductivity
- Low thermal expansion coefficient
- High Young's modulus
- Easy availability, manufacturability and above all low cost

1.7. Chronological Development of Cutting Tools

Cutting tools are in continuous stage and have reached a glorious stage to cope of with modern development of science and technology.

A Chronological development of cutting tool materials are given as follows

1. High speed steel
2. Carbides

3. Ceramics
4. UCON
5. Coated Carbides
6. Cubic Boron Nitride (CBN)
7. Diamond

Out of the above materials coated carbides serves as the new generation material to meet the present needs where most of the research is for use. Carbides which serve almost 60 to 80% of machining needs have taken the market of machining in particular ferrous materials.

1.8. Coatings

Machining efficiency is improved by reducing the machining time with high speed machining. But the softening temperature and the chemical stability of the tool material limits the cutting speed. When cutting ferrous and hard to machine materials such as steels, cast iron and super alloys, softening temperature and the chemical stability of the tool material limits the cutting speed. Therefore, it is necessary for tool materials to possess good high-temperature mechanical properties and sufficient inertness. While many ceramic materials such as TiC, Al₂O₃ and TiN possess high temperature strength, they have lower fracture toughness than that of conventional tool materials such as high-speed steels and cemented tungsten carbides. The machining of hard and chemically reactive materials at higher speeds is improved by depositing single and multi-layer coatings on conventional tool materials to combine the beneficial properties of ceramics and traditional tool materials. Coatings are diffusion barriers, they prevent the interaction between chip formed during the machining and the cutting material itself. The compounds which make up the coatings used are extremely hard and so they are very abrasion resistant. Typical constituents of coating are Titanium Carbide (TiC), Titanium Nitride (TiN), Titanium Carbonitride (TiCN) and alumina (Al₂O₃). All these compounds have low solubility in iron and they enable inserts to cut at much higher rate.

Carbide substrates are used because of their

- Higher Productivity by high speed machining
- Improved toughness and crack resistance by optimal dispersion of hard particles.
- Improved plastic deformation resistance and welding resistance for high cutting speed operations.

The effect of coatings are

- Reduction in friction
- Reduction in generated heat
- Reduction in cutting forces.
- Reduction in the diffusion between the chip and the surface of the tool, especially at higher speeds (the coating acts as a diffusion barrier).
- Prevention of galling, especially at lower cutting speeds.

In addition to increase the tool life, hard coating is deposited on cutting tools. The majority of cutting tools use chemical vapour deposition (CVD) or physical vapour deposition (PVD) hard coatings, which improves tool life and machining performance.

1.8.1. Types of Coating Technology

Surface coating of tribological applications is associated with deposition temperatures ranging from room temperature to over 1000°C. The coating thickness ranges from microns to several millimeters. Typically, the atomistic methods produce the thinnest coatings. Some methods involve high deposition temperatures that may give undesired phase transformations, softening or shape changes of the coated component. An important benefit of PVD and CVD processes is the high flexibility as to composition and structure of the coatings, and these processes are today successfully utilized to coat a large variety of mechanical components.

1.8.2. CVD (Chemical Vapour Deposition)

CVD method deposits thin films on the cutting tools through various chemical reactions. CVD coated cemented carbides have been a huge success since their introduction in the late 1960's. Since then, chemical vapour deposition technologies have advanced from single layer to multi-layer versions combining TiN, TiCN, TiC and Al₂O₃. Modern CVD coatings combine high temperature and medium temperature processes in complex cycles that produce excellent wear resistant coatings with a total thickness of 4-20 µm. However, the high deposition temperature (950-1059°C) during CVD results in diffusion of chemical elements from the carbide substrate to the coating during growth. The main effect is an embrittlement of the coating edge. In addition, the chemistry of the CVD process results in more rapid growth at the cutting edge resulting in an even coating thickness. Therefore, there was a strong driving force to find coatings that could be deposited at lower temperatures in order to allow tools with sharper edges to be coated without any embrittlement effect. The solution is PVD where deposition temperature can be kept at around 500°C.

1.8.3. How does CVD Works?

Chemical vapour deposition is a chemical process used to produce high-purity, high-performance solid materials. In a typical CVD process, the wafer (substrate) is exposed to one or more volatile precursors, which react and/or decompose on the substrate surface to produce the desired deposit. Frequently, volatile by-products are also produced, which are removed by gas flow through the reaction chamber. Microfabrication processes widely use CVD to deposit materials in various forms, including: monocrystalline, polycrystalline, amorphous, and epitaxial. These materials include: silicon, carbon fiber, carbon nanofibers, filaments, carbon nanotubes, SiO₂, silicon-germanium, tungsten, silicon carbide, silicon nitride, silicon oxynitride, titanium nitride, and various high dielectrics. The CVD process is also used to produce synthetic diamond. It is a chemical process used to produce high-purity, high-performance solid materials. The results show that the CVD coating has to be used to improve the production.

1.8.4. PVD (Physical Vapour Deposition)

PVD method deposits thin films on the cutting tools through physical techniques, mainly sputtering and evaporation. PVD coatings, with deposition temperatures of 400-600°C, are gaining greater acceptance in the market place. Over the last decade, they have been successfully applied to carbide metal cutting inserts. They offer performance advantage in applications involving interrupted cuts, those requiring sharp edges, as well as finishing and other applications. Depending on the intended application, different PVD technologies such as electron beam evaporation, sputtering and arc evaporation are used. Improvements in these technologies such as high ionization magnetron sputtering and new cathodic arc processes have further improved the performance of PVD coated tools. The metal cutting performance of PVD coated tools depend strongly on the composition, microstructure, internal stresses and adhesion of the coating to the substrate as well as the substrate composition and tool geometry. PVD process chain includes pre-PVD processes and post PVD-processes. Pre-treatment processes such as plasma etching and chemical etching influence adhesion, grain growth, stress at substrate surface and coating structure, whereas post-PVD processes influence smoothness of coating surface and better chip flow. PVD coatings attribute excellent cutting performance to cemented carbide inserts. The reason that PVD has more and more taken over with regards to deposition of many coatings is the advantages that lower coating temperatures give with regard to micro-toughness.

1.8.5. Advantages of CVD coated carbides

- A wide range of applications from low to high speed and finishing to roughing.
- Stable Machining is obtained due to high toughness and crack resistant.
- Possible to reduce machining time and maintain good chip control with various chip breakers.

1.9.Types of Coating

1.9.1. Single Layer Coating

The first coating was a single layer of TiC. 10 to 12 micrometers thick, which was deposited by a process known as chemical vapour deposition (CVD) onto a substrate of hard metal. During the deposition process some carbon was taken up from the surface of the hard metal as part of coating and this changed the carbon balance at the junction of the coating and the hard metal substrate. This lowering of the carbon balance caused the formation of a brittle compound at the interface between the coating and the substrate and made early coated indexable inserts sensitive to chipping of cutting edge. The next development was to put down a coating of TiN which prevented any decarburising of the hard metal substrate but the coating which is gold in colour, did not adhere well to the hard metal base. TiN is an even better diffusion barrier than TiC but TiC has better abrasion resistance.

1.9.2. Multi-Layer Coatings

Although single-layer coatings are finding a range of applications in many sectors of engineering, there are an increasing number of applications where the properties of a single

material are not sufficient. One way to surmount this problem is to use a multilayer coating that combines the attractive properties of several materials, each chosen to solve a problem in the application. Multi-layer coatings can consist of as many as eight layers with in a total thickness of 10 micrometers or less. Simple examples of this include the use of interfacial bonding layers to promote adhesion, or thin inert coatings on top of wear-resistant layers to reduce the corrosion of cutting tools. There is, however, mounting evidence that the multilayer structure produced when many alternating layers of two materials are deposited can lead to improvements in performance over a mixed coating (by virtue of the introduction of new interfaces) even if the two materials do not have specific functional requirements in the intended application.

1.9.3. Why TiN ?

The majority of inserts presently used in various metal cutting operations are carbide tools coated with nitrides (TiN, CrN, etc.). The TiN deposited as a mono-layer holds a dominant position in the field of hard coatings. TiN coating is usually used as an outermost layer. As

- it increases the wear resistance
- reduces the sticking of the work material
- the golden color of the TiN coating helps in wear detection by allowing the operator to distinguish between a used and a new cutting edge come.

1.10. Tool wear

The prediction and control of wear is one of the most essential problems emerging in the design of cutting operations. A useful definition for a worn out tool is: “A tool is considered to be worn out when the replacement cost is less than the cost for not replacing the tool”. Tool failure is said to occur when the tool no longer performs the desired function whereas total failure (ultimate failure) is defined as the complete removal of the cutting edge, a condition obtaining when catastrophic failure occurs. Therefore, in machining operations, tools are considered to be worn out and are changed long before total to avoid incurring high costs associated with such catastrophic failures. The tool may experience repeated impact loads during interrupted cuts, and the work piece chips may chemically interact with the tool materials. The useful life of a cutting tool may be limited by a variety of wear processes such as crater wear, flank wear or abrasive wear, built up edge, notching and nose wear. Flank wear is observed on the flank or clearance face of a metal cutting insert and is caused mainly by abrasion of the flank face by the hard constituents of the workpiece. Crater wear is observed on the rake face of cutting tools and is caused by chemical interaction between the rake face of a metal cutting insert and the hot metal chip flowing over the tool.

The use of coating materials to enhance the performance of cutting tools is not a new concept. Coated hard metals have brought tremendous increase in productivity since their introduction in 1969 and had an immediate impact on the metal cutting industries. Due to their significantly higher hardness, carbide-cutting tools are more widely used in the manufacturing industries today than high-speed steels. Coated and uncoated carbides are

widely used in the metal working industry and provide the best alternative for most turning operations. Due to their heat resistance, cemented carbides can be used in very hot applications and all types of PVD and CVD processes can be used to deposit coatings. The combined substrate-coating properties determine the important properties such as wear, abrasion resistance and adhesion strength of a coating. A hard ware resistant coating cannot perform well unless complimented by a hard and tough substrate. Thus, a hard coating deposited on a soft substrate leads to poor properties. Physically and chemically vapor deposited coatings offer today a powerful alternative to improve further the cutting performance of the cutting materials. It is necessary for tool materials to possess high temperature strength. While many ceramic materials such as TiC, Al₂O₃ and TiN possess high temperature strength, they have lower fracture toughness than that of conventional tool materials such as high-speed steels and cemented tungsten carbides. The machining of hard and chemically reactive materials at higher speeds is improved by depositing single and multi-layer coatings on conventional tool materials to combine the beneficial properties of ceramics and traditional tool materials. Machining of metals is a complex process. The cutting tool environment features high-localized temperatures and high stress. The tool may experience repeated impact loads during interrupted cuts, and the work piece chips may chemically interact with the tool materials. The useful life of a cutting tool may be limited by a variety of wear processes such as crater wear, flank wear or abrasive wear, built up edge, depth of cut notching and nose wear. Flank wear is observed on the flank or clearance face of a metal cutting insert and is caused mainly by abrasion of the flank face by the hard constituents of the workpiece.

CHAPTER-2
LITERATURE REVIEW

The engineers have to face challenge in order to get optimal parameters for preferred output using available sources. Usually selection of machining parameters is very much difficult for desired product. Actually, it depends upon experience of the engineers and the table given by machine-tool designer. So, the importance of optimization arises in order to satisfy economy and quality of machined part.

The Taguchi's method tells about reduction in variation in order to improve quality by method of offline or online quality control. The offline quality control helps in improving quality of processes, where online quality control helps in maintaining conformance to the original or intended design. The main and fundamental part of Taguchi's design is to ensure that the product perform well even in noise; it helps in making the product long lasting. Taguchi method is applied in a very short period of time without lots of efforts. That is why Taguchi's method is adopted in various industries in order to improve the process quality in manufacturing sectors. Surface roughness and cutting force are two very important parameters in machining process. Cutting force is necessary for calculation of power machining. Cutting forces influences dimensional accuracy, deformation of work-piece and chip formation. Components of certain surface roughness are always required in industries as per customer requirement. This can be achieved by optimization process which we are going to discuss about. Here, the experts of machining gave their opinions regarding obtained results. A numerous study has been carried out regarding turning operation and the applied optimization techniques.

K. P. Warhode et al. [1] have optimized process parameter for material remove rate, power utilization and machining time using response surface methodology. The work piece material used for in progress investigation is Al6063 aluminium alloy. The experiments were conducted by using Taguchi L27 orthogonal array by in view of the machining restriction such as speed, feed and depth of cut. The result has indicated that it is feed rate which has significant influences both MRR and machining time and for power utilization speed is most chief parameter.

Nithyanandhan T. et al. [2] have investigated the property of progression parameters on surface finish and material removal rate (MRR) to obtain the best setting of progression parameters. And the analysis of Variance (ANOVA) is also used to analyze the influence of cutting parameters throughout machining. In this work, AISI 304 stainless steel work pieces are turned on conventional lathe by using tungsten carbide tool. The results exposed that the feed and nose radius is the most notable process parameters on work piece surface roughness. though, the depth of cut and feed are the significant factors on MRR.

D. Philip Selvaraj et.al. [3] have studied the Taguchi optimization method was functional to find the most favourable process parameters, which minimizes the surface roughness for the duration of the dry turning of AISI 304 Austenitic Stainless Steel. The Taguchi orthogonal array, the signal to noise S/N ratio and the investigation of variance ANOVA were used for the optimization of cutting parameters. The ANOVA results shows that feed rate, cutting speed and depth of cut affects the surface irregularity by 51.84%,

41.99% and 1.66% respectively. A verification experiment was also conducted and confirmed the success of the Taguchi optimization process.

Madhav Murthy A et al. [4] has studied the result of changing cutting constraint on surface finish using Taguchi method. In this learn the selected cutting parameter are cutting speed, feed, depth of cut and nose radius. Taguchi method with L16 orthogonal array (four factors and two levels) was used for experimentation and Analysis was done by Analysis of variance and regression equation has been adopted for predicting the surface roughness. Result show that, the factor feed rate is the most significant in influencing the surface roughness while the left over three factors measured are not significant. It was found that minimum surface roughness obtained at minimum nose radius, feed rate and maximum cutting speed.

Ravindra Thamma [5] have developed and comparing multi regression models by collecting data pertaining to depth of cut, nose radius, feed rate, surface roughness and cutting speed during turning of AL6061 aluminium alloy. Full factorial design of experiment procedure was used to develop the surface roughness regression model, within the range of selected parameter. The study reveals that cutting speed, feed and nose radius have major impact on surface roughness. Also depth of cut has significant impact on surface roughness in an interaction with other parameter.

K. krishnamurthy et al. [6] performed experiment to investigate the effect of machining parameter on surface roughness and material remove rate of TiB₂ particles reinforced aluminum (Al6063) metal. Four parameter namely cutting speed, feed, depth of cut and material are varied to study their effect on surface roughness and material remove rate. Experiment were conducted based on Taguchi L27 orthogonal array and then followed by optimization of the result using Analysis of variance to find out maximum material remove rate and minimum surface roughness. The best MRR was got when locating the cutting speed and feed rate at high values but low surface roughness obtained at high cutting speed and low feed rate.

JitendraVerma et. al. [7] have taken ASTM A242 type-1 ALLOY steel of 250 mm length as well as 50 mm diameter of material for testing using a CNC lathe machine. L9 array taken and for analyzed the data not only Taguchi but also ANOVA approach used. They done that speed (57.47% contribution) is the most noteworthy factor affecting surface roughness as well as followed by feed (23.46% contribution). Cutting speed is the least momentous factor affecting surface roughness.

Hari Singh et. al. [8] optimized setting of turning process parameters as depth of cut, cutting speed as well as feed rate giving in an optimal value of the feed force when machining EN24 steel among TiC-coated tungsten carbide inserts. The material of EN24 is a medium-carbon lowalloy steel and gets its typical applications in the manufacturing of machine tool parts. The L27 orthogonal array used for the study. They found that the percent help of depth of cut (55.15 %) and feed rate (23.33 %) in distressing the variation of feed force are notably larger as compared to the contribution of the cutting speed (2.63 %).

Syung Lan [9] present the optimization of cutting parameter –speed, feed, depth of cut and nose radius in order to improve surface finish and MRR orthogonal array has been adopted for planning of trial and multi objective optimization by using TOPSIS. It was observing that superior cutting speed, feed, depth of cut and minimum nose radius gives better surface finish and higher MRR. The result achieved by proposed multi purpose optimization technique, show that surface roughness and MRR increases about 27.80 %and 21.45 % respectively.

Tejinder pal singh [10] has investigated influence of cutting tool parameter such as tool rake angle, nose radius, and the clearance angle on surface roughness in turning operation using single point cutting tool. Aluminium was used for testing. The arithmetical models were developed to predict the effect of various tool parameters on surface roughness. Coefficient and adequacy of the urbanized model has been checked using student's 't' and 'f' test respectively at 95%. From this study it was found that surface roughness decreases with the increases in rake angle and also increase with increases in the nose radius.

Thamizhmanii et al. [11] applied Taguchi method for finding out the optimal value of surface roughness under optimum cutting condition in turning SCM 440 alloy steel. The experiment was designed by using Taguchi method and experiments were conducted and results thereof were analyzed with the help of ANOVA (Analysis of Variance) method. The causes of poor surface finish as detected were machine tool vibrations, tool chattering whose effects were ignored for analyses. The authors concluded that the results obtained by this method would be useful to other researches for similar type of study on tool vibrations, cutting forces etc. The work concluded that depth of cut was the only significant factor which contributed to the surface roughness.

Ozel et al.[12] carried out finish turning of AISI D2 steels (60 HRC) using ceramic wiper (multi-radii) design inserts for surface finish and tool flank wear investigation. For prediction of surface roughness and tool flank wear multiple linear regression models and neural network models were developed. Neural network based predictions of surface roughness and tool flank wear were carried out, compared with a non-training experimental data and the results thereof showed that the proposed neural network models were efficient to predict tool wear and surface roughness patterns for a range of cutting conditions. The study concluded that best tool life was obtained in lowest feed rate and lowest cutting speed combination.

Wang and Lan [13] used Orthogonal Array of Taguchi method coupled with grey relational analysis considering four parameters viz. speed, cutting depth, feed rate, tool nose run off etc. for optimizing three responses: surface roughness, tool wear and material removal rate in precision turning on an ECOCA-3807 CNC Lathe. The MINITAB software was explored to analyze the mean effect of Signal-to-Noise (S/N) ratio to achieve the multi-objective features. This study not only proposed an optimization approaches using Orthogonal Array and grey relational analysis but also contributed a satisfactory technique for improving the multiple machining performances in precision CNC turning with profound insight.

Fnides et.al.[14] studied on machining of slide-lathing grade X38CrMoV5-1 steel treated at 50 HRC by a mixed ceramic tool (insert CC650) to reveal the influences of cutting parameters: feed rate, cutting speed, depth of cut and flank wear on cutting forces as well as on surface roughness. The authors found that tangential cutting force was very sensitive to the variation of cutting depth. It was observed that surface roughness was very sensitive to the variation of feed rate and that flank wear had a great influence on the evolution of cutting force components and on the criteria of surface roughness.

KAdarsh Kumar et.al [15] focused on the analysis of optimum cutting conditions to get lowest surface roughness in facing by regression analysis. This present paper presents an experimental study to investigate the effects of cutting parameters like spindle speed, feed and depth of cut on surface finish on EN-8. A multiple regression analysis (RA) using analysis of variance is conducted to determine the performance of experimental measurements and to it shows the effect of cutting parameters on the surface roughness. Multiple regression modeling was performed to predict the surface roughness by using machining parameters. The investigation of influence of cutting conditions in facing operation of EN-8 in this paper. Machining was done using cemented carbide insert. The objective was to establish correlation between cutting speed, feed rate and depth of cut and optimize the turning conditions based on surface roughness. These correlations are obtained by multiple regression analysis (RA).

Mittal PBrahmbhatt et.al [16] illustrated the performance of MTCVD multicoated carbide insert in dry turning of EN9 steel. The effect of insert and cutting parameter on surface roughness and MRR is investigated. The experiments were conducted at three different spindle speed, feed and depth of cut. The cutting parameters are optimized using Taguchi method and the effect of cutting parameters and tool material on surface roughness was evaluated by the analysis of variance. The analysis indicated that the parameter that have the biggest effect on surface roughness and MRR is feed.

AnandS.Shivade, et.al [17] presentd the single response optimization of turning parameters for Turning on EN8 Steel. Experiments are designed and conducted based on Taguchi's L9 Orthogonal array design. This paper discusses an investigation into the use of Taguchi parameter Design optimize the Surface Roughness and Tool tip temperature in turning operations using single point carbide Cutting Tool. The Analysis of Variance (ANOVA) is employed to analyze the influence of Process Parameters during Turning. The useful results have been obtained by this research for other similar type of studies and can be helpful for further research works on the Tool life.

Neerajsharma et.al [18],The present study applied extended Taguchi method through a case study in straight turning of mild steel bar using HSS tool for the optimization of process param. The study aimed at evaluating the best process environment which could simultaneously satisfy requirements of both quality as well as productivity with special emphasis on reduction of cutting tool flank wear, because reduction in flank wear ensures increase in tool life. The predicted optimal setting ensured minimization of surface roughness.

From the present research of ANOVA it is found the Depth of cut is most significant, spindle speed is significant and feed rate is least significant factor effecting surface roughness.

K Saravankumar et.al [19] aimed at conducting experiments on Inconel 718 and investigation the influence of machining process parameters such as cutting speed (X1, m/min), feed rate(X2, mm/rev), and depth of cut (X3, mm) on the output parameters such as material removal rate and surface roughness.

P.P.Shirpurkar et.al [20] studied the effects of cutting speed, feed rate, depth of cut, nose radius and cutting condition on surface roughness and vibration chatter in the turning were experimentally investigated. EN 24 steel was machined using carbide tool on CNC lathe machine. The settings of turning parameters were determined by using Taguchi's experimental design method. Orthogonal arrays of Taguchi, the signal-to-noise (S/N) ratio, the analysis of variance (ANOVA) are employed to find the optimal levels and to analyze the effect of the turning parameters. Results show that Nose Radius and the Cutting Speed and cutting condition are the three Parameters that influence the Surface Roughness more effectively. Finally, the ranges for best cutting conditions are proposed for serial industrial production.

F Jafarian et.al [21] proposed a useful and effective method to determine optimal machining parameters in order to minimize surface roughness, resultant cutting forces and maximize tool life in the turning process. At first,three separate neural networks were used to estimate outputs of the process by varying input machining parameters. Then, these networks were used as optimization objective functions. Moreover, the proposed algorithm, namely, GA and PSO were utilized to optimize each of the outputs, while the other outputs would also be kept in the suitable range. The obtained results showed that by using trained neural networks with genetic algorithms as optimization objective functions, a powerful model would be obtained with high accuracy to analyze the effect of each parameter on the output(s) and optimally estimate machining conditions to reach minimum machining outputs.

P Venkata Ramaiah et.al [22] made an attempt is made to obtain optimum turning parameters for minimum cutting forces and cutting temperature by using Fuzzy Logic. In this work, turning is performed on Al 6061 work material under dry conditions with CNMG cutting tool according to Taguchi experimental design. The Experimental responses like cutting temperature and cutting force are measured for different influential parameter combinations. The Experimental data is analyzed using Fuzzy Logic and optimum parameters combination is determined. The optimum parameters combination is tested by confirmation experiment and the result is satisfactory.

MAdinarayana et.al [23] envisages the study to optimize the effects of process variables on surface roughness, MRR and power consumption of En24 of work material using PVD coated tool. In the present investigation the influence of spindle speed, feed rate, and depth of cut were studied as process parameters. The experiments have been conducted using full factorial design in the design of experiments (DOE) on a conventional lathe. A Model has been developed using regression technique. The optimal cutting parameters for

minimum surface roughness, maximum MRR and minimum power consumption were obtained using Taguchi technique. The contribution of various process parameters on response variables have been found by using ANOVA technique.

Yacov sahijpaul et.al [24] done experimental investigation to analyse the effect of controlled cutting parameters namely cutting speed, feed rate, depth of cut, cutting fluid concentration and two cutting fluids with different base oils on surface roughness (Ra) of EN8 or AISI 1040 steel during turning operation by applying design of experiments, custom design method, analysis of variance, leverage plots and desirability profiling using JMP software to optimize surface roughness during wet CNC turning operation. The analysis reveals that feed rate has the most significant effect on surface roughness (Ra) and value of surface roughness does not significantly differ for two different cutting fluids used.

Vaibhav B. Pansare et.al [25] attempt is made to obtain optimum turning parameters for minimum surface roughness value by using Ant Colony Optimization (ACO) algorithm in multipass turning operation. The cutting process has roughing and finishing stage. Also the relationship between the parameters and the performance measures were determined using multiple linear regression, this mathematical model is used to determine optimal parameters. The experimental results shows that the proposed technique is both effective and efficient.

Er Sandeep Kumar et.al [26] Engineering materials are presently in use at a very vast range in today's industries. As Mild steel 1018 has a wide variety of applications in construction of pipelines, products, construction as structural steel, car manufacturing industries and other major industries. The machining of these types of materials requires very important consideration. There are a number of parameters like cutting speed, feed and depth of cut etc. which must be given consideration during the machining of this alloy. So it becomes necessary to find out the ways by which it can be machined easily and economically. For the present work the parameter to be optimized selected is material removal rate that is optimized by using selected combination of machining parameters by using taguchi orthogonal array.

Girish Tilak Shet et.al [27] presented the optimization of surface roughness parameters in turning EN1A steel on a CNC lathe. In this work, the Taguchi methods, a powerful statistical tool to design of experiments for quality, is used to find the optimal cutting parameters for turning operations. Analysis of Variance has been used to determine the influencing parameters on the output responses. Using Taguchi technique, we have reduced number of experiments from 27 to 9 there by the total cost of the project is reduced by 66.66%. The results obtained are encouraging and the concluding remarks are helpful for the manufacturing industries.

Anderson P. Paiva et al.[28] have been conduct experiment on AISI 52100 with different parameter like cutting speed (V), feed rate (f) and depth of cut (d) .The outputs considered were: the mixed ceramic tool life (T), processing cost per piece (Kp), cutting time (Ct), the total turning cycle time (Tt), surface roughness (Ra) and the material removing rate (MRR). The aggregation of these targets into a single objective function is conducted using

the score of the first principal component PC of the responses“ correlation matrix and the experimental region is used as the main constraint of the problem. Considering that the first principal component cannot be enough to represent the original data set, a complementary constraint defined in terms of the second principal component score (PC2) is added. The original responses have the same weights and the multivariate optimization lead to the maximization of MRR while minimize the other outputs. The kind of optimization assumed by the multivariate objective function can be established examining the eigenvectors of the correlation matrix formed with the original outputs. The results indicate that the multi response optimization is achieved at a cutting speed of 238 m/min, with a feed rate of 0.08 mm/rev and at a depth of cut of 0.32 mm.

S. PalDey et.al [29] have discussed the wear resistant properties of (Ti,Al)N for various machining applications as compared with coatings such as TiN, Ti(C,N) and (Ti,Zr)N. Tey have found that the high hardness (28_32 GPa), relatively low residual stress (/5GPa), high oxidation resistance, high hot hardness, and low thermal conductivity make (Ti,Al)N coatings most desirable in dry machining and machining of abrasive alloys at high speeds. Multicomponent coatings based on different metallic and nonmetallic elements such as, Cr and Y drastically improve the oxidation resistance, Zr and V improve the wear resistance, whereas, Si increases the hardness, boron improves the abrasive wear behaviour and resistance to chemical reactivity of the film. The presence of a large number of interfaces between individual layers of a multilayered structure results in a drastic increase in hardness and strength. So it is possible to design new wear resistant or functional coatings based on a multilayer or a multi component system to meet the demanding applications of advanced materials.

J.A. Ghani et.al [30] investigated the wear mechanism of TiN-coated carbide and uncoated cermets tools at various combinations of cutting speed, feed rate, and depth of cut for hardened AISI H13 tool steel. They have observed that the time taken for the cutting edge of TiN-coated carbide tools to initiate cracking and fracturing is longer than that of uncoated cermets tools, especially at the combinations of high cutting speed, feed rate, and depth of cut and at the combinations of low cutting speed, feed rate, and depth of cut, the uncoated cermets tools show more uniform and gradual wear on the flank face than that of the TiN-coated carbide tools.

Tugrul O zel et.al [31] presented the effects of cutting edge preparation geometry, workpiece surface hardness and cutting conditions on the surface roughness and cutting forces in the finish hard turning of AISI H13 steel. They have found that the cutting forces are influenced not only by cutting conditions but also the cutting edge geometry and workpiece surface hardness. The lower workpiece surface hardness and small edge radius resulted in lower tangential and radial forces.

J.A. Arsecularatne et.al [32] described an experimental investigation on machining of a difficult-to-cut material, AISI D2 steel of hardness 62 HRC with PCBN tools. They have found that most of the tested PCBN tools reached the end of life mainly due to flank wear. The highest acceptable values of tool life and volume of material removal were obtained at

the lowest speed tested (70 m/min) but the highest feed used resulted in the highest volume of material removal, lower feeds resulted in higher tool life values.

Ibrahim Ciftci [33] presented the results of experimental work in dry turning of austenitic stainless steels (AISI 304 and AISI 316) using CVD multilayer coated cemented carbide tools. The cutting tools used were TiC/TiCN/TiN and TiCN/TiC/Al₂O₃ coated cemented carbides. They found out that the cutting speed significantly affects the machined surface roughness values. With increasing cutting speed, the surface roughness values decreased until a minimum value is reached beyond which they increase.

Abhijeet S. Morea et.al [34] have proposed that PCBN is the dominant tool material for hard turning applications due to its high hardness, high wear resistance, and high thermal stability. They have presented the result that the flank wear is mainly due to abrasive actions of the martensite present in the hardened AISI 4340 alloy. The crater wear of the cBN–TiN coated inserts is less than that of the PCBN inserts because of the lubricity of TiN capping layer on the cBN–TiN coating.

J. Rech [35] found out that various coatings deposited on a carbide insert has shown the sliding properties of the TiN and (Ti, Al)N+MoS₂ coatings, compared to uncoated tools in the context of high-speed dry turning of steels. TiN and (Ti, Al)N+MoS₂ coatings reduce the tool–chip contact area, the thickness of the secondary shear zone and the temperature at this interface, which reduce the heat flux transmitted to the cutting tool substrate.

Renato Francisco de A vila et.al [36] tested the performance of uncoated and coated carbide tools (ISO grade K10) with a 3 μm thick monolayer of TiN (produced by PAPVD) when continuous turning AISI 8620 steel. Their results indicate that two distinct crater wear rates are present when machining using coated cutting tools, whereas a higher and single wear rate was identified for the uncoated inserts.

C.H. Che Haron et.al [37] investigated the tool life and wear behaviour at various machining parameters. Coated carbide (KC 9125) and uncoated carbide (K 313) were used in turning tool steel AISI D2 bar with hardness of 25 HRC and have found that the wear progression for both type of carbide tools experienced three stages of wear rate, namely; initial, gradual and abrupt stages of wear mechanism. Slow wear rate and uniform flank wear were observed at low feed rate of 0.05 mm/rev. Generally, coated tool performed better as compared to uncoated tool. A good surface finish and longer tool life were achieved using coated tool.

A.K. Chattopadhyay et.al [38] studied the wetting characteristics of aluminium towards different cutting tool materials by using uncoated carbide (94%WC+6%Co) and mono or multi-layer coated carbide tools with top coating of TiC, TiN, Al₂O₃ and diamond. observed that aluminium had tendency to wet uncoated carbide (94% WC+6%Co) inserts. However, wetting was more pronounced when surface was enriched with cobalt. Coatings like TiC, TiN or Al₂O₃ could not show pure nonwetting characteristics for aluminium. Turning test with aluminium indicated heavy material built up on uncoated (94%WC+6%Co) tool.

Abhay Bhatt et.al [39] presented the results of an experimental investigation on the wear mechanisms of uncoated tungsten carbide(WC) and coated tools (single-layer(TiAlN)PVD, and triplelayer (TiCN/Al₂O₃/TiN) CVD) in oblique finish turning of Inconel718. It was found that the abrasive and adhesive wear were the most dominant wear mechanisms, controlling the deterioration and final failure of the WC tools and the triple layer CVD coated tools exhibited the highest wear resistance at high cutting speeds and low feeds and the uncoated tools outperformed the single and multi-layer coated tools in the low range of cutting speeds and intermediate feeds.cutting speeds.

Kyung-Hee Park et.al [40] have analyzed the flank wear on the multi-layer (TiCN/Al₂O₃/TiCN) coated carbide inserts while turning AISI 1045 steel using advanced microscope and image processing techniques including wavelet transform,they have obtained the flank wear profiles and analyzed the surface roughness and groove sizes on the coating layers. The dominant wear mechanism was found to be the abrasion by the cementite phase in the work material. They concluded that the hardness of the coating is the most important requirement to resist flank wear due to its high wear resistance against abrasion.

M.A. El Hakim et.al [41] They have presented the performance of four cutting tool in the machining of medium hardened HSS: polycrystallinec-CBN (CBN-TiN), TiNcoated polycrystallinec-CBN (CBN-TiN), ceramic mixed alumina (Al₂O₃-TiC), and coated tungsten carbide (TiN coated over a multilayer coating (TiC/TiCN/Al₂O₃)) and have found that the high chemical and thermal stability of Al₂O₃ tribo-films protects the tool substrate because it prevents the heat generated at the tool/chip interface from entering the tool core.

R. Suresh et.al [42] have analyzed the effects of process parameters on machinability aspects by using multilayer hard coatings (TiC/TiCN/Al₂O₃) on cemented carbide substrate for machining of hardened AISI 4340 and have found that the optimal combination of low feed rate and low depth of cut with high cutting speed is beneficial for reducing machining force. Higher values of feed rates are necessary to minimize the specific cutting force. The machining power and cutting tool wear increases linearly with increase in cutting speed and feed rate. The combination of low feed rate and high cutting speed is necessary for minimizing the surface roughness. Abrasion was the principle wear mechanism observed at all the cutting conditions.

CHAPTER-3
METHODOLOGY

3.1. Taguchi Method

Taguchi has developed a methodology for the application of designed experiments, including a practitioner's handbook. This methodology has taken the design of experiments from the exclusive world of the statistician and brought it more fully into the world of manufacturing. His contributions have also made the practitioner work simpler by advocating the use of fewer experimental designs, and providing a clearer understanding of the variation nature and the economic consequences of quality engineering in the world of manufacturing. Taguchi introduces his approach, using experimental design for:

- designing products/processes so as to be robust to environmental conditions
- designing and developing products/processes so as to be robust to component variation;
- minimizing variation around a target value.

The philosophy of Taguchi is broadly applicable. He proposed that engineering optimization of a process or product should be carried out in a three-step approach, i.e., system design, parameter design, and tolerance design.

In system design, the engineer applies scientific and engineering knowledge to produce a basic functional prototype design, this design including the product design stage and the process design stage. In the product design stage, the selection of materials, components, tentative product parameter values, etc., are involved. As to the process design stage, the analysis of processing sequences, the selections of production equipment, tentative process parameter values, etc., are involved. Since system design is an initial functional design, it may be far from optimum in terms of quality and cost. The objective of the parameter design is to optimize the settings of the process parameter values for improving performance characteristics and to identify the product parameter values under the optimal process parameter values. In addition, it is expected that the optimal process parameter values obtained from the parameter design are insensitive to the variation of environmental conditions and other noise factors. Therefore, the parameter design is the key step in the Taguchi method to achieving high quality without increasing cost.

Basically, classical parameter design, developed by Fisher, is complex and not easy to use. Especially, a large number of experiments have to be carried out when the number of the process parameters increases. To solve this task, the Taguchi method uses a special design of orthogonal arrays to study the entire parameter space with a small number of experiments only. A loss function is then defined to calculate the deviation between the experimental value and the desired value. Taguchi recommends the use of the loss function to measure the performance characteristic deviating from the desired value. The value of the loss function is further transformed into a signal-to-noise (S/N) ratio g . Usually, there are three categories of the performance characteristic in the analysis of the S/N ratio, that is, the lower-the-better, the higher-the-better, and the nominal-the-better. The S/N ratio for each level of process parameters is computed based on the S/N analysis. Regardless of the category of the performance characteristic, the larger S/N ratio corresponds to the better performance characteristic. Therefore, the optimal level of the process parameters is the level with the

highest S/N ratio \bar{y} . Furthermore, a statistical analysis of variance (ANOVA) is performed to see which process parameters are statistically significant. With the S/N and ANOVA analyses, the optimal combination of the process parameters can be predicted. Finally, a confirmation experiment is conducted to verify the optimal process parameters obtained from the parameter design. In this paper, the cutting parameter design by the Taguchi method is adopted to obtain optimal machining performance in turning.

$$\text{Nominal is the best: } S/N_T = 10 \log \left(\frac{\bar{y}}{s_y^2} \right) \quad (1)$$

$$\text{Larger-is-the better(maximize): } S/N_L = -10 \log \left(\frac{1}{n} \sum_{i=1}^n \frac{1}{y_i^2} \right) \quad (2)$$

$$\text{Smaller-is-the better(minimize): } S/N_S = -10 \log \left(\frac{1}{n} \sum_{i=1}^n y_i^2 \right) \quad (3)$$

where \bar{y} is the average of observed data, s_y^2 is the variance of y , n is the number of observations and y is the observed data. Notice that these S/N ratios are expressed on a decibel scale. We would use S/NT if the objective is to reduce variability around a specific target, S/NL if the system is optimized when the response is as large as possible, and S/NS if the system is optimized when the response is as small as possible. Factor levels that maximize the appropriate S/N ratio are optimal. The goal of this research was to produce minimum surface roughness (Ra) in a turning operation. Smaller Ra values represent better or improved surface roughness. Therefore, a smaller-the-better quality characteristic was implemented and introduced in this study.

The use of the parameter design of the Taguchi method to optimize a process with multiple performance characteristics includes the following steps:

- Identify the performance characteristics and select process parameters to be evaluated. Determine the number of levels for the process parameters and possible interactions between the process parameters.
- Select the appropriate orthogonal array and assignment of process parameters to the orthogonal array.
- Conduct the experiments based on the arrangement of the orthogonal array.
- Calculate the total loss function and the S/N ratio.
- Analyze the experimental results using the S/N ratio and ANOVA.
- Select the optimal levels of process parameters.
- Verify the optimal process parameters through the confirmation experiment.

3.2. Analysis of Variance (ANOVA)

The purpose of the ANOVA is to investigate which of the process parameters significantly affect the performance characteristics. This is accomplished by separating the variability of the S/N ratios, which is measured by the sum of the squared deviations from the total mean of the S/N ratio, into contributions by each of the process parameters and the error. First, the total sum of the squared deviations SST from the total mean of the S/N ratios can be calculated as

$$\begin{aligned} SS_T &= \sum_{i=1}^m (\eta_i - \bar{\eta})^2 = \sum_{i=1}^m \eta_i^2 - \sum_{i=1}^m 2\eta_i\bar{\eta} + \sum_{i=1}^m \bar{\eta}^2 \\ &= \sum_{i=1}^m \eta_i^2 - 2m\bar{\eta}^2 + m\bar{\eta}^2 = \sum_{i=1}^m \eta_i^2 - m\bar{\eta}^2 \\ &= \sum_{i=1}^m \eta_i^2 - \frac{1}{m} [\sum_{i=1}^m \eta_i]^2 \end{aligned}$$

where ‘m’ is the number of experiments in the orthogonal array, e.g., m = 9 and η_i is the mean S/N ratio for the i^{th} experiment.

The total sum of the squared deviations SS_T is decomposed into two sources: the sum of the squared deviations SS_P due to each process parameter and the sum of the squared error SS_e . SS_P can be calculated as:

$$SS_P = \sum_{j=1}^t \frac{(S\eta_j)^2}{t} - \frac{1}{m} \left[\sum_{i=1}^m \eta_i \right]^2$$

where ‘p’ represent one of the experiment parameters, j the level number of this parameter p, t the repetition of each level of the parameter p, $s\eta_j$ the sum of the S/N ratio involving this parameter p and level j.

The sum of squares from error parameters SS_e is

$$SS_e = SS_T - SS_A - SS_B - SS_C$$

The total degrees of freedom is $DT = m - 1$, where the degrees of freedom of the tested parameter $D_p = t - 1$. The variance of the parameter tested is $V_p = SS_P/D_p$. Then, the F-value for each design parameter is simply the ratio of the mean of squares deviations to the mean of the squared error ($FP = V_p/V_e$). The corrected sum of squares SP can be calculated as:

$$\hat{S}_p = SS_P - D_p V_e$$

The percentage contribution q can be calculated as:

$$P = \frac{\hat{S}_p}{SS_T}$$

Statistically, there is a tool called the F-test named after Fisher to see which process parameters have a significant effect on the performance characteristic. In performing the F-test, the mean of the squared deviations SS_m due to each process parameter needs to be calculated. The mean of the squared deviations SS_m is equal to the sum of the squared deviations SS_d divided by the number of degrees of freedom associated with the process parameter. Then, the F-value for each process parameter is simply a ratio of the mean of the squared deviations SS_m to the mean of the squared error SS_e . Usually the larger the F-value,

the greater the effect on the performance characteristic due to the change of the process parameter.

CHAPTER-4
EXPERIMENTAL DETAILS

The experimental steps involved in the present work are clearly explained in this chapter. This includes selection of work material, selection of process parameters and their levels and selection of appropriate orthogonal array etc.

4.1 Selection of Work Material:

The work material selected for the study is stainless steel of grade SS316. The work specimens are of cylindrical shape and are shown in figure 4.1. The work material has a wide range of applications in furnace parts, heat exchangers, jet engine parts, valve and pump parts, photographic equipment's, tanks and evaporators etc. The chemical composition and mechanical properties of SS316 are given in the tables 4.1 and 4.2.



Figure 4.1. SS316 material

Table 4.1: Chemical Composition of SS316

C	Mn	Si	p	S	Cr	Mo	Ni	Fe
0.0-0.07	0.0-2.0	0.0-1.0	0.0-0.05	0.0-0.02	16.50-18.50	2.00-2.50	10.00-13.00	Remaini ng

Table 4.2: Mechanical Properties of SS316

Density (Kg/m ³)	Tensile strength (mpa)	Yield Strength (mpa)	Elongation (%)	Hardness (BHN)
8000	500-700	200min	40	215

4.2 Selection of the Process Parameters and Their Levels

Selection of right combination of process parameters and setting the range of the process parameters is very important step in unconventional process. Small variation in process parameters will effect adversely on the Surface Roughness and accuracy of the machined components. In general the process parameters are of two types:

- Fixed parameters
- Controlled parameters

In this present work the tool geometry, work pieces hardness and its mechanical properties and environmental conditions are taken as fixed parameters which will not be changed throughout the investigations, whereas Tool type, cutting speed, feed and depth of cut are controlled as the controlled parameters are used to change for each experiment by Taguchi approach. The selected process parameters for the experiment with their limits, notations and units are given in table 4.3.

Table 4.3: Process Parameters and Their Levels

	parameter	1	2	3
A	Tool type	Non-coated	coated	-
B	Speed (RPM)	900	1200	1500
C	Feed (mm/rev)	0.03	0.06	0.09
D	Depth of cut (mm)	0.4	0.8	1.2

4.3 Selection of Orthogonal Array (OA)

Taguchi has developed a design called orthogonal array it is used to study the entire design space with a very less number of experiments. For the four parameters with mixed levels taguchi's standard L18 has been choosen and it is given in the table 4.4

Table 4.4: Taguchi L18 Orthogonal Array

S.No.	A	B	C	D
1	Non-coated	900	0.03	0.4
2	Non-coated	900	0.06	0.8
3	Non-coated	900	0.09	1.2
4	Non-coated	1200	0.03	0.4
5	Non-coated	1200	0.06	0.8
6	Non-coated	1200	0.09	1.2
7	Non-coated	1500	0.03	0
8	Non-coated	1500	0.06	1.2
9	Non-coated	1500	0.09	0.4
10	coated	900	0.03	1.2
11	coated	900	0.06	0.4
12	coated	900	0.09	0.8
13	coated	1200	0.03	0.8
14	coated	1200	0.06	1.2
15	coated	1200	0.09	0.4
16	coated	1500	0.03	1.2

17	coated	1500	0.06	0.4
18	coated	1500	0.09	0.8

4.4 Selection of Tools

The tools selected for the study are tungsten carbide Non-coated tool and tungsten carbide Coated tool as shown in figures 4.2 and 4.3. The Coating is done using physical vapour deposition (PVD).



Figure 4.2 Non coated Tool



Figure 4.3 Coated Tool

The experiments were conducted on CNC turret lathe it is shown in the figure 4.4. The work pieces are first trued 0.5 mm to remove the unevenness and the components after machining were shown in the figure 4.5. After machining the finished components were tested for their surface roughness with SJ-210 tester shown in figure 4.6.



Figure 4.4 CNC Machine



Figure 4.5 Machined Workpieces



Figure 4.6 SJ-210 Roughness Tester

CHAPTER-5
RESULTS AND DISCUSSIONS

In this chapter the experimental results of Material Removal Rate (MRR) and Surface Roughness (Ra) are analyzed using Taguchi and Anova methods. The focus of the work is to identify the optimal combination of process parameters that concurrently maximizes the material removal rate and minimizes the surface roughness.

5.1 Experimental Results

After conducting the experiment's, the results of material removal rate and surface roughness measured were depicted in table 5.1.

Table 5.1: Experimental Results

S.NO	MRR (cm ³ /sec)	Ra (μm)
1	0.01350	0.215
2	0.02885	0.442
3	0.04696	0.573
4	0.01684	0.246
5	0.04140	0.761
6	0.05824	0.556
7	0.02594	0.315
8	0.05298	0.365
9	0.02807	1.190
10	0.02317	0.196
11	0.02211	0.291
12	0.03578	0.585
13	0.02307	0.195

14	0.03610	0.291
15	0.02355	0.367
16	0.03500	0.294
17	0.02004	0.275
18	0.03171	0.608

5.2 Taguchi and ANOVA Analysis of MRR:

Taguchi analysis was conducted for the responses using Higher-the-Better and Lower-the-Better characteristics. The results of taguchi analysis of Mrr were given in table 5.2. From the mean values of the process parameters the main effect plots of Mrr were drawn and shown in figure 5.1.

Table 5.2: Response Table for Means of Mrr

Level	Tool Type	S	F	D
1	0.02784	0.02840	0.02291	0.02068
2	0.03475	0.03319	0.03358	0.03113
3		0.03229	0.03739	0.04207
Delta	0.00691	0.00480	0.01447	0.02140
Rank	3	4	2	1

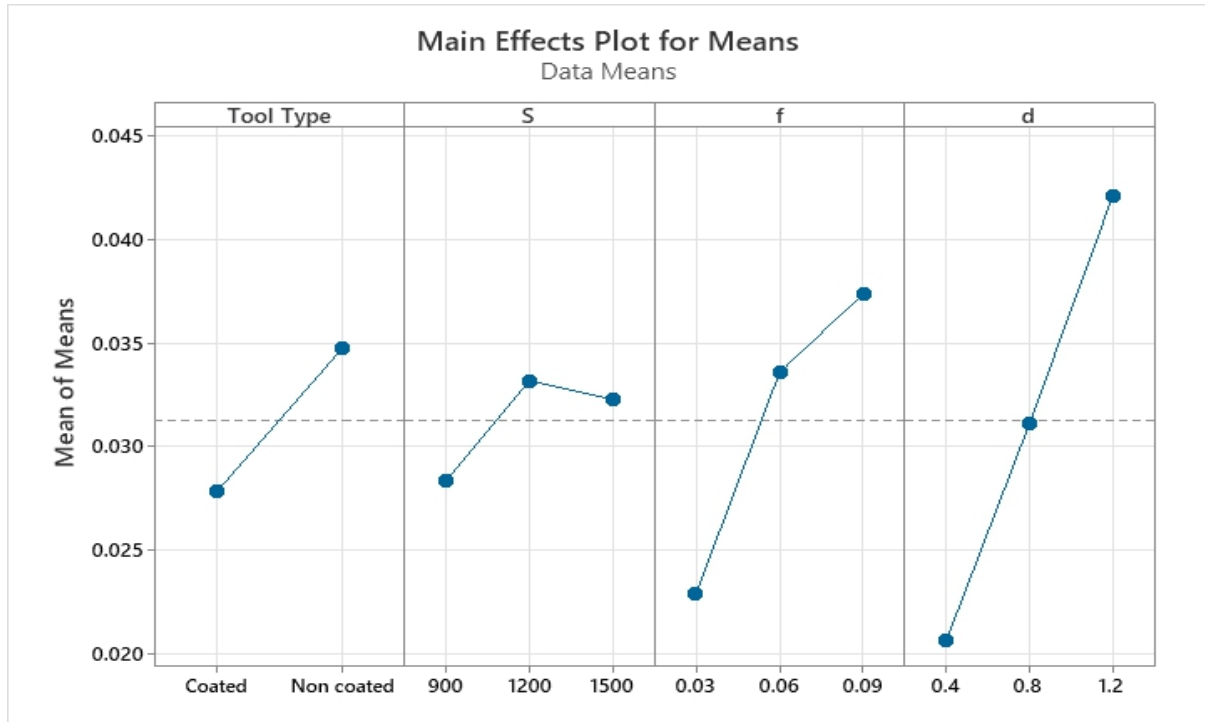

Figure 5.1 Main Effects Plots For Means of MRR

From the Main effect plot analysis the optimal combination of process parameters for achieving maximum material removal rate is found at

Tool type: Level1, Non Coated

Speed: Level2, 1200 RPM

Feed: Level3, 0.09 mm/rev

Depth of cut: Level3, 1.2mm

Table 5.3 : Analysis of Variance for MRR

Source	DF	Adj SS	Adj MS	F-Value	P-Value
Tool Type	1	0.000215	0.000215	9.14	0.013
S	2	0.000078	0.000039	1.66	0.239
F	2	0.000675	0.000338	14.35	0.001
D	2	0.001374	0.000687	29.19	0.000
Error	10	0.000235	0.000024		
Total	17	0.002577			

ANOVA results of the responses for Mrr were given in table 5.3 respectively. From the results it is observed that depth of cut and feed are the most significant factors for the responses respectively.

5.3 Regression Model and Residual Plots for MRR :

Regression analysis has been conducted to prepare models for the responses .The residual plots were drawn to analyse the distribution of errors. From the normality (figure 5.2) and versus fits and order plots for responses, it is concluded that the residuals are not following normality and they are not showing any regular pattern hence the models developed are accurate and adequate.

5.3.1 Regression Equation for MRR

$$\text{Mrr} = 0.03129 - 0.00346 \text{ Tool Type_Coated} + 0.00346 \text{ Tool Type_Non coated} - 0.00290 \text{ S_900} + 0.00190 \text{ S_1200} + 0.00100 \text{ S_1500} - 0.00838 \text{ f_0.03} + 0.00229 \text{ f_0.06} + 0.00609 \text{ f_0.09} - 0.01061 \text{ d_0.4} - 0.00017 \text{ d_0.8} + 0.01078 \text{ d_1.2}$$

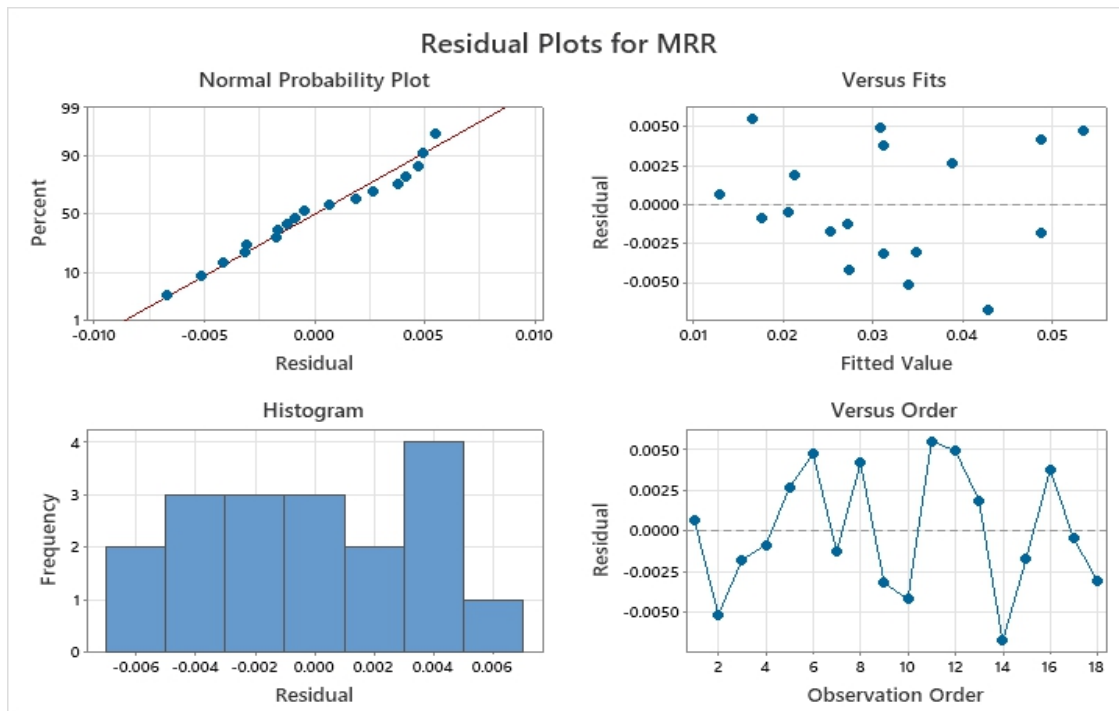

Figure 5.2: Residual plots for MRR

5.4 Taguchi and ANOVA Analysis for Ra:

Taguchi analysis was conducted for the responses using Higher-the-Better and Lower-the-Better characteristics. The results of taguchi analysis of Ra were given in table 5.4. From the mean values of the process parameters the main effect plots of Ra were drawn and shown in figure 5.3.

Table 5.4 : Response Table for Means of Ra

Level	Tool Type	S	F	D
1	0.3447	0.3837	0.2435	0.4307
2	0.5181	0.4027	0.4042	0.4843
3		0.5078	0.6465	0.3792
Delta	0.1734	0.1242	0.4030	0.1052
Rank	2	3	1	4

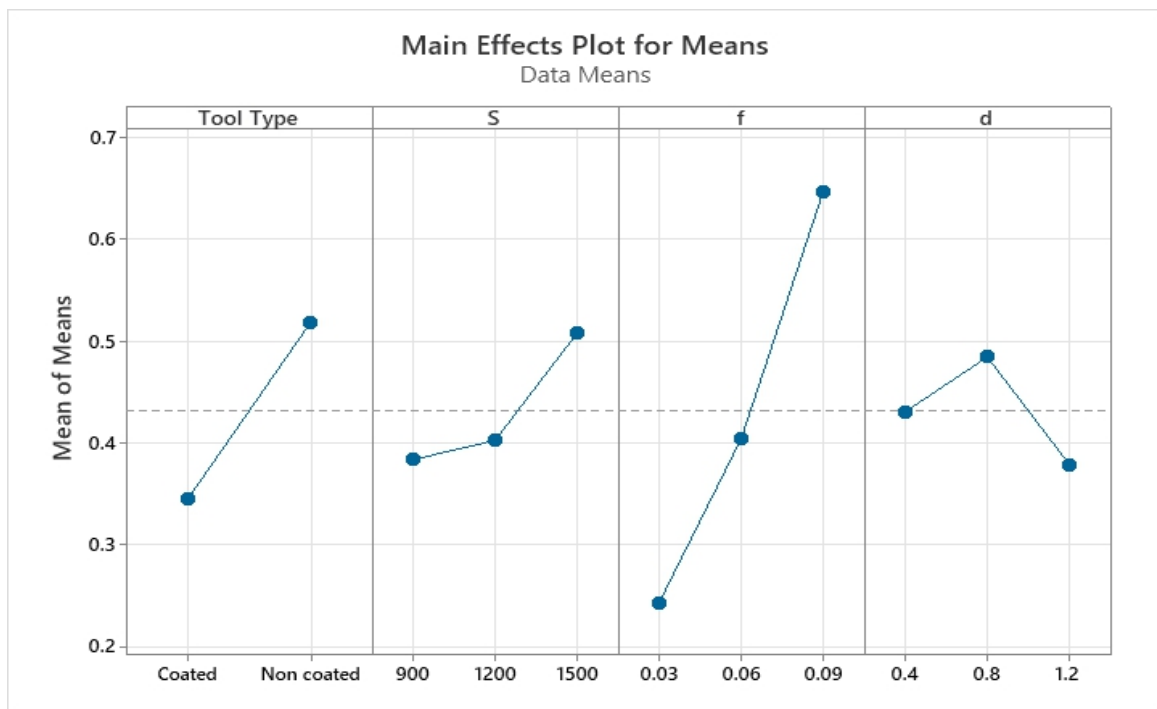

Figure 5.3 : Main Effects Plots for Means of Ra

From the main effect plot analysis the optimal combination of process parameters for achieving minimum surface roughness is found at

Tool type: Level1, Coated

Speed: Level1, 900 RPM

Feed: Level1, 0.03 mm/rev

Depth of cut: Level3, 1.2 mm

Table 5.5 : Analysis of Variance for Ra

Source	DF	Adj SS	Adj MS	F-Value	P-Value
Tool Type	1	0.13537	0.13537	3.80	0.080
S	2	0.05368	0.02684	0.75	0.495
F	2	0.49390	0.24695	6.94	0.013
D	2	0.03318	0.01659	0.47	
Error	10	0.35582	0.03558		
Total	17	1.07195			

ANOVA results of the responses for Ra were given in table 5.5 respectively. From the results it is observed that depth of cut and feed are the most significant factors for the responses respectively.

5.5 Regression Model and Residual Plots for Ra:

Regression analysis has been conducted to prepare models for the responses. The residual plots were drawn to analyse the distribution of errors. From the normality (figure 5.4) and versus fits and order plots for responses, it is concluded that the residuals are not following normality and they are not showing any regular pattern hence the models developed are accurate and adequate.

5.5.1 Regression Equation for Ra

$$\begin{aligned} Ra = & 0.4314 - 0.0867 \text{ Tool Type_Coated} + 0.0867 \text{ Tool Type_Non Coated} - 0.0477 \text{ S_900} \\ & - 0.0287 \text{ S_1200} + 0.0764 \text{ S_1500} - 0.1879 \text{ f_0.03} - 0.0272 \text{ f_0.06} + 0.2151 \text{ f_0.09} \\ & - 0.0007 \text{ d_0.4} + 0.0529 \text{ d_0.8} - 0.0522 \text{ d_1.2} \end{aligned}$$

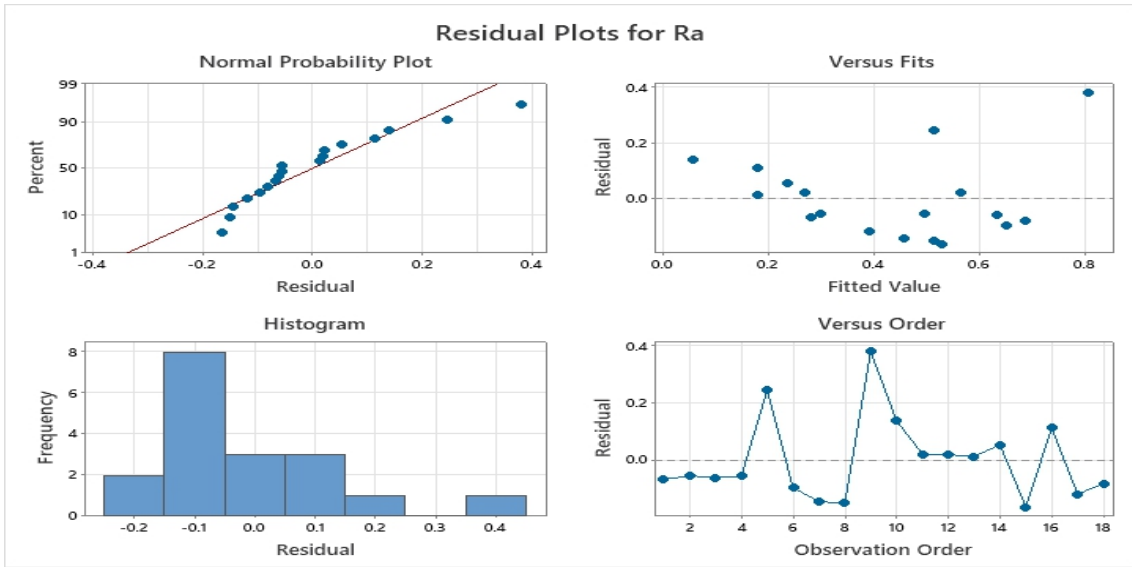

Figure 5.4 :Residual plots for Ra

CHAPTER-6

CONCLUSIONS

The optimal combination of process parameters for Material Removal Rate and Surface Finish are found as:

1. For MRR, Tool type: Non Coated, Speed: 1200 Rpm, Feed: 0.09 mm/rev, Depth of Cut: 1.2 mm respectively.
2. For Ra, Tool type: Coated, Speed: 900 Rpm, Feed: 0.03 mm/rev, Depth of Cut: 1.2 mm respectively.
3. From the results of ANOVA, it is found that depth of cut and feed are the most influencing factor for Material Removal Rate and Surface Finish respectively.
4. The Regression models prepared for the both responses showed good agreement with the experimental results as they followed normality and constant variance hence the models prepared can be used effectively for the future prediction of responses.

CHAPTER-7
REFERENCES

1. Khushboo P. Warhade, sonam K. bhilare, “Modeling and analysis of machining process using Response Surface Methodology”, International Journal of Emerging trend in Engineering and Development ,Issue 3,Vol.2(March 2013),ISSN 2249-6149.
2. Nithyanandhan T. et al “Optimization of Cutting Forces, Tool Wear and Surface Finish in Machining of AISI 304 Stainless Steel Material Using Taguchi’s Method”, International Journal of Innovative Science, Engineering & Technology, Vol. 1 Issue 4, June 2014, page 488-493 .
3. D. Philip Selvaraj et al “Optimization of surface roughness of AISI 304 austenitic stainless steel in dry turning operation using Taguchi method”, Journal of Engineering Science and Technology Vol. 5, No. 3 (2010) page 293 – 301, © School of Engineering, Taylor’s University College
4. Madhav Murthy A , K.Mallikharjuna Babu and R.Suresh Kumar A “Optimization of Machinability Parameters of Al6061 using Taguchi Technique”, International Journal of Current Engineering and Technology ,ISSN 2277 – 4106, 16 March 2014, PP62- 64.
5. Ravindra Thamma(2008) “Comparison Between Multiple Regression Models To Study Effect Of Turning Parameters On The Surface Roughness” , Proceedings of The 2008 IAJC-IJME International Conference, ISBN 978-1-60643-379 9,pp133
6. K.Krishnamurthy, J.Venkatesh, “Assessment of Surface Roughness and Material Removal Rate on Machining of TIB 2 Reinforced Aluminum 6063 Composites: A Taguchi’s Approach” International Journal of Scientific and Research Publications, Volume 3, Issue 1, January 2013,PP:1-6
7. JitendraVerma, Pankaj Agrawal &LokeshBajpai, “Turning Parameter Optimization for Surface Roughness of ASTM A242 type-1 Alloys Steel by Taguchi Method”, International Journal of Advances in Engineering & Technology, March 2012.
8. Hari Singh & Pradeep Kumar, “Optimizing feed force for turned parts through the Taguchi technique”,SadhanaVol. 31, Part 6, pp. 671–681, 2006
9. Tian-Syung lan , “Taguchi Optimization Of MultiObjective CNC Machining Using TOPSIS” Information Technology Journal 8 (6),ISSN 1812-5638, 917- 922,2009.
10. Tejinder pal Singh, Jagtar Singh, Jatinder Madan, “Effect of Cutting Tool Parameter On Surface Roughness” ,International Journal of Mechanical Engineering And Technology,Vol-1,No.-1,JulyAug(2010,) pp.182-189.
11. ThamizhmaniiS., Saparudin S. and Hasan S., (2007), “Analysis of Surface Roughness by Using Taguchi Method”, Achievements in Materials and Manufacturing Engineering, Volume 20, Issue 1-2, pp. 503-505.
12. Özel T. and Karpaz Y., (2005), “Predictive modeling of surface roughness and tool wear in hard turning using regression and neural networks”, International Journal of Machine Tools and Manufacture, Volume 45, pp. 467–479.

13. Wang M. Y. and Lan T. S., (2008), "Parametric Optimization on Multi-Objective Precision Turning Using Grey Relational Analysis". *Information Technology Journal*, Volume 7, pp.1072-1076.
14. Fnides B., Aouici H., Yallese M. A., (2008), "Cutting forces and surface roughness in hard turning of hot work steel X38CrMoV5-1 using mixed ceramic", *Mechanika*, Volume 2, Number 70, pp. 73-78.
15. K.AdarshKumar,Ch.Ratnam,BSNMurthy,B.SatishBen,K.Raghu Ram Mohan Reddy 'Optimization Of Surface Roughness In Face Turning Operation In Machining of EN-8' *International Journal Of Engineering Science and Advanced Technology*(ISSN 2250-3676,Volume 2,Issue 4,March 2013).
16. Mittal p Brahmbhatt,Mr.Ankit R Patel. Mr.Priyank S Panchal'Optimization of Cutting Parameters For Dry Turning Of EN 9 Steel With MTCVD Multicoated Carbide Insert Using Taguchi Method.' *International Journal Of Advanced Engineering and Research Development*(ISSN 2348-6406,Volume 1,Issue 5,May 2014).
17. AnandS.Shivade,Shivraj Bhagat .SurajJagdale, AmitNikam, Pramod Londhe'Optimization Of Machining Parameters For Turning Using Taguchi Method' *International Journal Of Recent Technology and Engineering*(ISSN 2230-3476,Volume 2,Issue 4,March 2013).
18. Neerajsharma,Renu Sharma 'Optimization Of Process Parameter Of turning Parts:A Taguchi Approach' *Journals Of Engineering ,Computers And Applied Sciences*(ISSN 2319-5606,Volume 1,Issue 1,October 2012).
19. K.Saravankumar,M.RPratheesh Kumar 'Optimization Of CNC Turning Process Parameters On INCONEL 718 Using Genetic Algorithm.' *Engineering Science And Technology:An International Journal(ESTIJ)*(ISSN 2250-3498,Volume 2,Issue 4,August 2012)
20. P.P.Shirpurkar,P.DKamble,S.RBobde,V.V.Patil'Optimization Of CNC Turning Process parameters For Prediction Of Surface Roughness By Taguchi Orthogonal Array'. *International journal of engineering research and technology(ijert)*(issn 2278-0181,volume 3,issue 1,january 2014)
21. F. Jafarian, M. Taghipour and H. Amirabadi'Application of artificial neural network and optimization algorithms for optimizing surface roughness, tool life and cutting forces in turning operation.' *Journal of Mechanical Science and Technology*(ISSN 1469-1477,Volume 2 Issues 4,January 2013).
22. P. VenkataRamaiah, N. Rajesh, K. Dharma Reddy 'Determination of Optimum Influential Parameters in Turning of Al6061 using fuzzy logic.' *International Journal of Innovative Research in Science,Engineering and Technology*(ISSN 2319-8753,Volume 2 Issues 10,October 2013).

23. M.Adinarayana, G.Prasanthi, G.Krishnaiah 'Multi Objective Optimization during Turning of EN24 Alloy Steel.' *Int. Journal of Engineering Research and Applications*.(ISSN 2248-9622,Volume 3 Issues 5,October 2013).
24. Yacovsahijpaul, Gurpreetsingh 'Determining the Influence of Various Cutting Parameters on Surface Roughness during Wet CNC Turning Of AISI 1040 Medium Carbon Steel.' *IOSR Journal of Mechanical and Civil Engineering (IOSR-JMCE)*(ISSN 2278-1684,Volume 7 Issues 2,June 2013).
25. Vaibhav B. Pansare, Mukund V. Kavade 'Optimization of cutting parameters in multipass turning operation using ant colony algorithm.' *International journal of engineering science & advanced technology*(ISSN 2250–3676,Volume 2 Issues 4,June 2013).
26. Er. Sandeep Kumar, Sushil Kumar Sharma 'Optimization of Material Removal Rate in Cnc Turning of Mild Steel 1018 Using Taguchi Method.' *Int. Journal of Engineering Research and Applications* (ISSN : 2248-9622, Vol. 4, Issue 4, April 2014).
27. GirishTilakShet,Dr.N. LashmanaSwamy, Dr. H.Somashekar 'Optimization of Surface Roughness Parameters in Turning EN1A Steel on A CNC Lathe Without Coolant.' *International Journal of Engineering Research & Technology (IJERT)*(ISSN : 2278-0181, Vol. 3 Issue 1, January2014
28. Quazi T Z,PratikMore,VipulSonawane 'A Case Study Of Taguchi Method In The Optimization Of Turning Parametr's' *International Journal Of Engineering Technology And Advanced Engineering*(ISSN 2250-2459,ISO 9001:2008,Volume 3,Issue 2,february 2013).
29. S. PalDey, S.C. Deevi, Single layer and multilayer wear resistant coatings of (Ti,Al)N, *Materials Science and Engineering A342* (2003) 58_ /79
30. J.A. Ghani , I.A. Choudhury, H.H. Masjuki. "Wear mechanism of TiN coated carbide and uncoated cermets tools at high cutting speed applications", *Journal of Materials Processing Technology* 153–154 (2004) 1067–1073.
31. Tugrul O" zel · Tsu-Kong Hsu · Erol Zeren, "Effects of cutting edge geometry, workpiece hardness, feed rate and cutting speed on surface roughness and forces in finish turningof hardened AISI H13 steel", *Int J Adv Manuf Technol* (2005) 25: 262–269.
32. J.A. Arsecularatne , L.C. Zhang , C. Montross , P. Mathew, On machining of hardened AISI D2 steel with PCBN tools, *Journal of Materials Processing Technology* 171 (2006) 244–252.
33. Ibrahim Ciftci, "Machining of austenitic stainless steels using CVD multi-layer coated cemented carbide tools", *Tribology International* 39 (2006) 565–569.
34. Abhijeet S. Morea, Wenping Jiang, W.D. Brownb, and Ajay P. Malshe, Tool wear and machining performance of cBN–TiN coated carbide inserts and PCBN compact inserts in

- turning AISI 4340 hardened steel, *Journal of Materials Processing Technology* 180 (2006) 253–262.
35. J. Rech, A multiview approach to the tribological characterisation of cutting tool coatings for steels in high-speed dry turning, *Int. J. Machining and Machinability of Materials*, Vol. 1, No. 1, 2006.
 36. Renato Francisco de A vila a, Alexandre Mendes Abra~o , G. Cristina Dura es de Godoy, The performance of TiN coated carbide tools when turning AISI 8620 steel, *Journal of Materials Processing Technology* 179 (2006) 161–164.
 37. C.H. Che Haron, J. A. Ghani, G.A. Ibrahim, K. Husin and T.S. Yong, Performance of coated and uncoated carbide tools in turning AISI D2, *Journal of Manufacturing and Material Processing*, (2006)65-70.
 38. A.K. Chattopadhyay, P. Roy, A. Ghosh, S.K. Sarangi, Wettability and machinability study of pure aluminium towards uncoated and coated carbide cutting tool inserts, *Surface & Coatings Technology* 203 (2009) 941–951.
 39. Abhay Bhatt, HelmiAttia , R.Vargas , V.Thomson, Wear mechanisms of WC coated and uncoated tools in finish turning of Inconel 718, *Tribology International* 43 (2010) 1113–1121.
 40. Kyung-Hee Park, Patrick Y. Kwon, Flank wear of multi-layer coated tool, *Wear* 270 (2011) 771–780.
 41. M.A. ElHakim , M.D.Abad , M.M.Abdelhameed , M.A.Shalaby , S.C.Veldhuis, Wear behavior of some cutting tool materials in hard turning of HSS, *Tribology International* 44 (2011) 1174–1181
 42. R. Suresh, S. Basavarajappa, G.L. Samuel, Some studies on hard turning of AISI 4340 steel using multilayer coated carbide tool, *Measurement xxx* (2012).
 43. A.V.N.L Sharma, K Venkatasubbaiah, P.S.N Raju ‘Parametric Analysis Of Multiobjective Optimization Of Cutting Parameters in Turning Operation Of EN353-With CVD Cutting Tool Using Taguchi Method’ *International Journal Of Engineering and Innovative Technology* (ISSN 2277-3754, ISO 9001:2008, Volume 2, Issue 9, March 2013).
 44. S. S. Chaudhari, S. S. Khedka and N. B. Borkar, “Optimization of Process Parameters Using Taguchi Method Approach with Minimum Quantity Lubrication for Turning”, *International Journal of Engineering Research and Applications*, vol. 4, (2011), pp. 1268.
 45. D. Selvaraj and P. Chandarmohan, “Optimization of Surface Roughness of AISI304 Austenitic Stainless Steel in Dry Turning Operation Using Taguchi Design Method”, *Journal of Engineering Science and Technology*, vol. 5, no. 3, (2010), pp. 293-301.
 46. Ch. Maheswara Rao, K. Jagadeeswara Rao and K. Suresh Babu, “Optimization of Material Removal Rate and Surface Roughness Using Grey Analysis” *International*

Journal of Engineering Research and Development, e-ISSN: 2278-067X, p-ISSN:2278-800X, Vol. 12, Issue 3, (Part-1), March 2016, pp. 49-58.

47. B. M. Gopaldaswamy, B. Mondal and S. Ghosh, “Taguchi Method and ANOVA: An Approach for Process Parameters Optimization of Hard Machining While Machining Hardened Steel”, Journal of Scientific and Industrial Research, vol. 68, (2009), pp. 686-695.
48. Ch. Maheswara Rao, K. Venkata Subbaiah and K. Jagadeeswara Rao, “Experimental Investigation of Surface Roughness Characteristics Ra, Rq and Rz”, International Journal of Hybrid Information Technology, ISSN: 1738-9968, Vol-9, No.7, 2016, pp.373-388.
49. N. E. Edwin Paul, P. Marimuthu and R. Venkatesh Babu, “Machining Parameter Setting for Facing EN 8 Steel with TNMG Insert”, American International Journal of Research in Science and Technology, Engineering & Mathematics, vol. 3, no. 1, (2013), pp. 87-92.
50. Ch. Maheswara Rao and K. Venkata Subbaiah, “Optimization of Surface Roughness in CNC Turning Using Taguchi method and ANOVA”, International Journal of Advanced Science and Technology, ISSN: 2005-4238, Vol-93, 2016, pp.1-14.
51. Ch.Maheswara Rao, K.Venkata Subbaiah, “Multi-Objective Optimization of Material Removal Rate and Surface Roughness in Dry Turning of Aluminium Alloy AA7075 Using Taguchi-Utility Method”, Journal of Recent Activities in Production, e-ISSN: 2581-9771, Vol.3, Issue.2, pp. 1-14, 2018.
52. S. S. Chaudhari, S. S. Khedka and N. B. Borkar, “Optimization of Process Parameters Using Taguchi Method Approach with Minimum Quantity Lubrication for Turning”, International Journal of Engineering Research and Applications, vol. 4, (2011), pp. 1268.
53. Ch.Maheswara Rao, P.Srikanth, S.Pavan Kumar, S.Sai Dinesh, M.Nagendra Kumar, “Parametric Optimization of Material Removal Rate and Surface Roughness Using Taguchi Method and RSM”, A Journal of Composition Theory, e-ISSN:0731-6755, Vol:13, Issue:2, pp.179-190, Feb-2020.

